

INSTRUCTION MANUAL

CL-68A Centre Lathe (415V) 800 x 3000mm - 130mm Bore



L625D

Operation Manual Contents

Specification	4
1. High Speed Precision Lathe	
1-1 Constructional Indication.....	8
2. Unpacking and Installation	
2-1 Points for Unpacking.....	10
2-2 Unloading of the Machine.....	10
2-3 Construction of the Ground.....	11
2-4 Cleaning.....	11
2-5 Level Adjustment.....	11
3. Electric Circuit Control	
3-1 Electric Wiring.....	16
3-2 Electric Device.....	16
3-3 Important Notes.....	16
4. Test Running	
4-1 Operation Symbols.....	20
4-2 Transmission and Stop of Main Spindle.....	21
4-3 Selecting Main Spindle Speed.....	21
4-4“Intermittent”Operation of Main Spindle.....	22
4-5 The Importance and Methods of Spindle Levelling Adjustment.....	22
4-6 Transmission and Stop of Gear Box.....	23
4-7 Operation of Gear Box.....	23
4-8 Manual Operation.....	23
4-9 Auto Feed Operation.....	24
4-10 Auto Feed Stop Operation.....	24
4-11 Four Position Auto Feed Stop Operation.....	24
4-12 Tailstock Operation.....	25
5. Cutting Threads	

5-1 Lead Screw Drive.....	26
5-2 Cutting Thread.....	26
5-3 Thread Dial Indicator.....	26
5-4 Thread and Feed Table.....	28
6. Lubrication	
6-1 Lubrication in Headstock.....	30
6-2 Lubricating in Gear Box and Apron.....	30
6-3 Useful Reference Lubricating Table for Other Mechanism.....	30
6-4 Lubrication Location.....	31
7. Maintenance & Servicing	
7-1 Headstock.....	32
7-2 Apron & Saddle.....	33
7-3 Gear Box.....	34
7-4 Adjustment of Tailstock Centering.....	34
7-5 Belt Tension Adjustment.....	34
7-6 Foot Brake Belt Adjustment.....	35
7-7 Brake and Micro Switch Adjustment.....	36
7-8 Adjustment to the Backlash of Lead screw.....	36
7-9 Maintenance for Cutting Liquid Coolant Pump.....	36
8. Chucks and Chuck Mounting.....	37
9. Preventive Maintenance.....	38
10. Trouble Shooting.....	41
11. Parts List Assembly.....	44-98

PACKING LIST		DOCUMENT		91ZD	
PRODUCT:		LATHE			
MODEL:		C6256			
SERIAL NUMBER:					
SPECIFICATIONS:		1500mm	2000mm	3000mm	
NET WEIGHT:		2370kg	2720kg	3430kg	
GROSS WEIGHT:		2740kg	3110kg	4000kg	
SET/CASE(L×W×H) (mm):		2900×1150×1740	3400×1150×1740	4400×1150×1740	
No	DESCRIPTION	SPECIFICATIONS		QTY	NOTE
1	LATHE	C6256		1	
2	REDUCTION SLEEVE	MORSE: DT 7/5		1	
3	FIXED CENTER	MORSE: DX 5		1	
4	ALLOY CENTER	MORSE: DG 5		1	
5*	LIVE CENTER	MORSE: DH 5		1	
6	CAM SPANNER	C6251A-15-03、C6251A-15-04		2	
7	TOOLREST SPANNER	12		1	
8	OPEN-ENDED SPANNER	6/7、8/10、9/11、11/13、12/14		6	
		17/19、22/24、27/30		2	
9	ALLEN KEY	2、2.5、3、4、5、6、8、10、12		4	
10	OIL GUN	180		1	
11	CROSS SCREWDRIVER	100×6		1	
12	STRAIGHT SCREWDRIVER	100×6		1	
13	GEARS (METRIC)	RUN460-104060 Mn=2 Z=11		1	
		RUN460-104062 Mn=2 Z=15		1	
		RUN460-104066 Mn=2 Z=18		1	
		RUN460-104067 Mn=2 Z=13		1	
14	CHANGE GEARS(METRIC)	C6256A-05-11Y Mn=2.5 Z=57		1	
		C6256A-15-01 Mn=2.5 Z=40		1	
		RUN6141-108007、RUN6141-108015		2	
15	CHANGE GEARS(IMPERIAL)	C6256A-15-01Y Mn=2.5 Z=42		1	
		C6256A-15-02Y Mn=2.5 Z=66		1	
		RUN6141-108002		1	
16	SHEAR PIN	RUN6246-106081		1	
17	SHEAR PIN	C6251A-01-16		1	
18	BLOCK-LEVELING	RUN6246-106069		6 or 8	8 for 3000mm
19	BOLT	RUN6246-106029		6 or 8	8 for 3000mm
20	NUT	M24×2 GB6173-86		6 or 8	8 for 3000mm
21	HANDLE	RUN6246-103030A		1	
22	HANDLE	RUN6246-103029		1	
23*	THREE-JAW CHUCK	φ 315mm		1	
24*	FOUR-JAW CHUCK	φ 350mm or φ 400mm		1	
25*	FACEPLATE	φ 450mm		1	
26*	CAMLOCK STUDS(USED IN	C6246B-101050		6	
27*	SCREW (USED IN FACEPLATE)	M8×12 GB70-85		6	
28*	CENTER STEADY REST			1	
29*	TRAVELLING STEADY REST			1	
30	QUALIFICATION CERTIFICATE			1	
31	INSTRUCTION MANUAL			1	
32	PACKING LIST			1	
NOTE: "*" IS FOR USERS' SPECIAL ORDER					
SURVEYOR:			DATE:		

Specification

Models C6251A×1000 / C6251A×1500 / C6251A×2000 / C6251A×3000

Capacity

Swing Over Bed	φ 510mm
Swing Over Cross Slide	φ 305mm
Swing in Gap Diameter×Width	735×170mm
Height of Center	255mm
Distance Between Centers	1000mm / 1500mm / 2000mm / 3000mm
Width of Bed	350mm
Cutting Tool Max. Section	25×25mm
Total Travel of Cross Slide	316mm
Total Travel of Top Slide	130mm

Headstock

Spindle Bore	φ 80mm
Spindle Nose	D1-8
Spindle Morse Taper in Nose, in Sleeve	M.T.No.7
Spindle Speeds Number	12
Spindle Speeds Range	25-1600r.p.m

Thread & Feeds

Lead screw Diameter & Thread	φ 40mm×4T.P.I. or Pitch 6mm
Threads Imperial Pitches	2-112 T.P.I. (60nos)
Threads Metric Pitches	0.2-14mm (47nos)
Diametrical Pitches	4-112D.P. (50nos)
Module Pitches	0.1-7M.P. (39nos)
Longitudinal Feeds Imperial	0.0022"-0.0612"/Rev (35nos)
Longitudinal Feeds Metric	0.059-1.646mm/Rev (35nos)
Cross-Feeds Imperial	0.00048"-0.01354" (35nos)
Cross Feeds Metric	0.020-0.573mm (35nos)

Tailstock

Total Travel of Tailstock Quill	180mm
Tailstock Quill Diameter	φ 75mm
Taper In Tailstock Quill	M.T.No.5

Motor

Spindle Drive Motor	7.5kW(10HP) 3PH
Coolant Pump Motor	0.1kW(1/8HP)

Weight & Measures

Machine Space Required

(L×W×H): cm 239×115×143 / 284×115×143 / 334×115×143 / 434×115×143

Packing Case Dimensions

(L×W×H): cm 245×115×174 / 290×115×174 / 340×115×174 / 440×115×174

Net Weight 2025kg / 2335kg / 2685kg / 3400kg

Gross Weight 2360kg / 2700kg / 3070kg / 3970kg



1. High Speed Precision Lathe

1-1 Constructional Indication

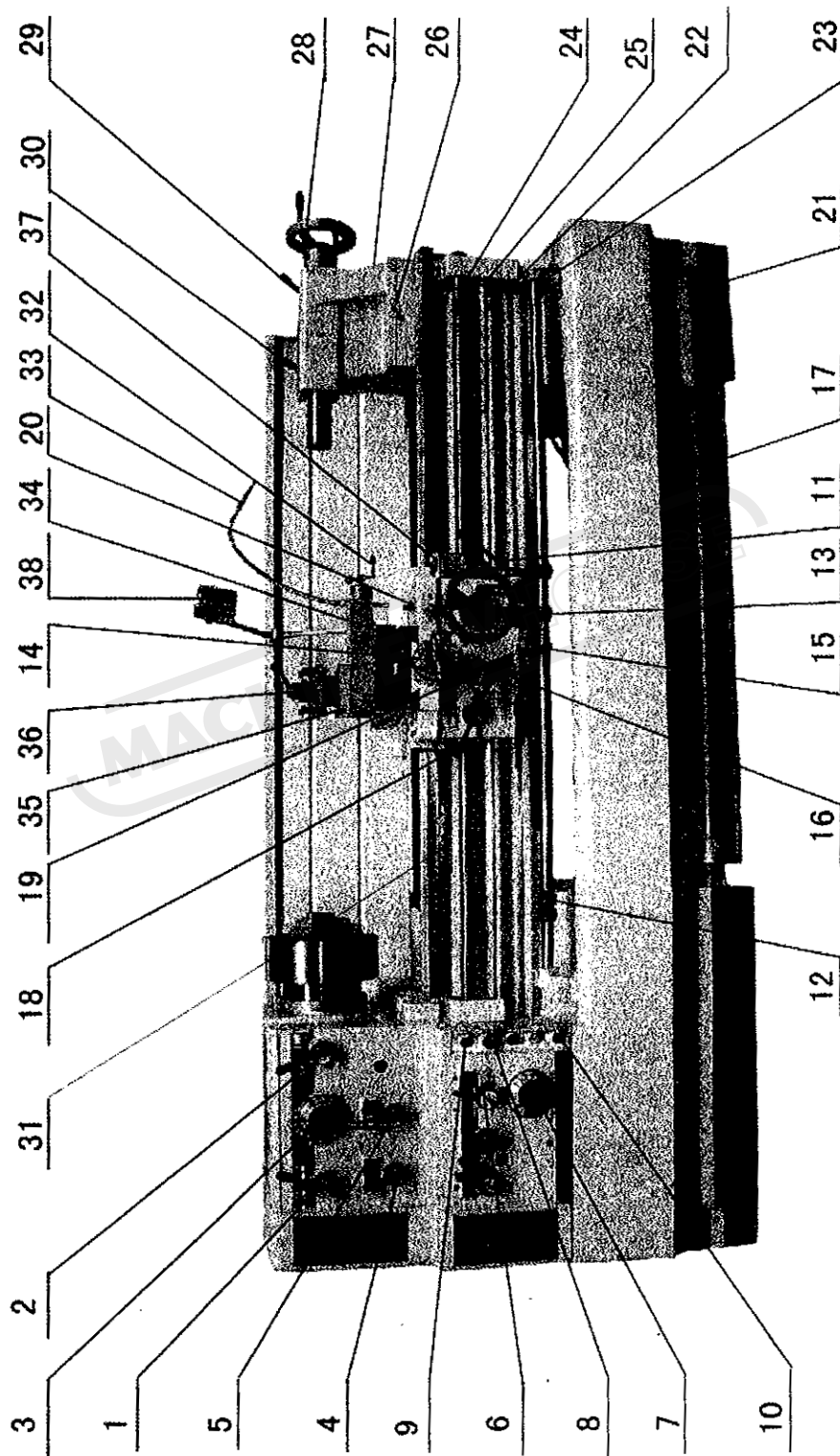

No.	Description	No.	Description
1	Main Spindle Speed Change Lever	20	Saddle Fixture Screws
2	High/Low Speed Change Lever	21	Foundation Adjustment Bolts
3	Main Spindle Speed Change Lever	22	Start Lever
4	Forward/Reverse Lever	23	4-Position Auto Stop Lever
5	Thread Feed Select Lever	24	Lead screw
6	Thread Feed Change Lever	25	Auto Feed Rod
7	10 Steps Feed Change Disc	26	Tailstock Set Over Adjust Screws
8	Power Switch	27	Tailstock Body
9	Intermittent Switch	28	Tailstock Hand-wheel
10	Coolant Pump Switch	29	Tailstock Body Clamping Lever
11	Start Spindle Control Knob	30	Tailstock Spindle Locking Lever
12	Eccentric Center Ring	31	Rack
13	Longitudinal Apron Hand-wheel	32	Compound Rest Handle
14	Cross Slide Feed Knob	33	Coolant Control Valve
15	Auto Stop Centering	34	Compound Rest
16	Auto Feed Lever	35	Four Way Tool Post
17	Foot Brake Pedal	36	Tool Post Clamping Lever
18	Half Nut Engaged Lever	37	Thread Dial Indicator
19	Feed Select Lever (Longitudinal & Cross Feed)	38	Lamp

2. Unpacking and Installation

2-1 Points for Unpacking

For short distance transportation of this machine, fix it onto the truck by hemp rope: while for long distance, packed by a wooden case or dispatched by container. Please first to check if there is any damage on packing when arrive. After unpacking carefully inspect whether it exists any injury or insufficiency. If any contact us immediately for proper settlement or any of the damages of the machine will receive no any compensation from us.

2-2 Unloading of the Machine

When the machine is unloaded from the car or to be moved, please proceed with following steps (as illustrated 2-2)

1) Preparing two round sticks (long approx.830mm dia 40mm) insert into the preserved holes on lathe bed. Then lift up with applying wires on both end of the stick.

2) Lifting the machine by a crane.

3) Before lifting adjust the position of Lathe Apron and Tailstock to maintain the balance of machine.

4) When the machine was shifted to its destination. always handle with care to put it down. Don't let go of it to hit the ground or it will affect the accuracy of the machine.

Note: Machine weight can be seen in Specification Table.

5) For the adjustment of electric control, keep the distance between machine and wall not less than 600mm.

illustration 2-2

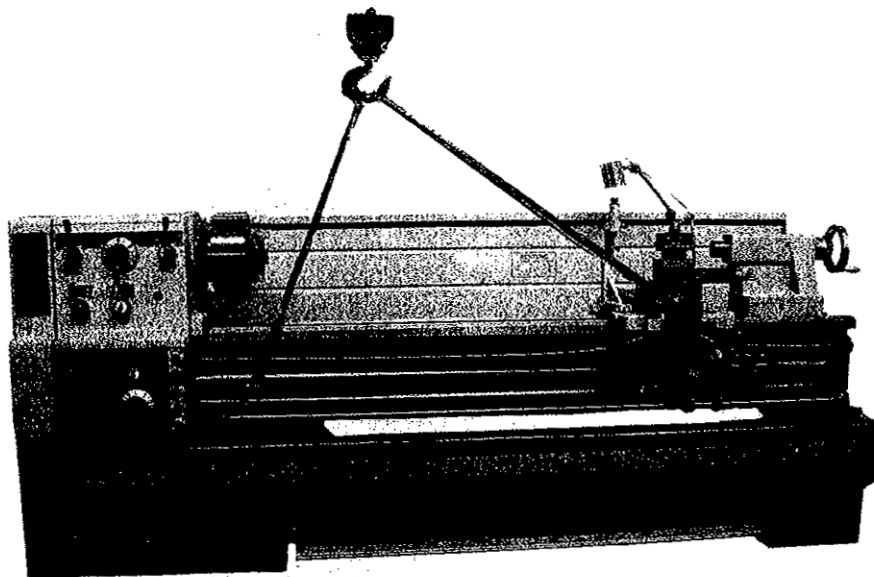

2-3 Construction of the Ground

Due to the recent tendency of utilizing Utilizing Ultra-Hard Alloy Steel tools, it surely increase the speed of heavy cutting comparing to the previous steel tools. But, in the mean time, it easily happens to the vibration of the machine. For assuring better cutting result, it requires a very strong and steady construction of ground. (Please refer to right illustration of construction of ground)

2-4 Cleaning

All our machine are with a anti-rust oil layer before delivery. After inspection, please remove to clean the slideways, lead screw, shafts and other polished parts by a soft cloth with cleanser (do not use gasoline or cellulose solvent to avoid fire or explosion). Then apply a thin layer of oil for lubricating purpose. Push those movable parts such as: Tool Holder, Tailstock back and forth.

2-5 Level Adjustments

Wait until the fixture screws and cement completely concrete to start adjusting lathe bed horizontally. In doing this, place a leveling instrument (with accuracy 0.02 mm/1000mm) upon the grooves of lathe bed to confirm the level of right and left side. Same procedure for the front and rear leveling.

The allowance of level should be adjusted within 0.04 mm/1000mm.

Screw up the nuts, check again, if whatever errors occur due to tightly screw-up thereafter, adjustment may require to be done again.

As per illustration indicated, place two leveling instruments on lathe bed to check the level by pushing them back and forth in its possible maximum moving range.

illustration 2-3

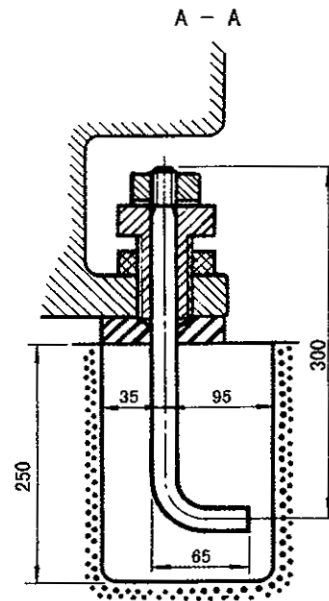

illustration 2-5

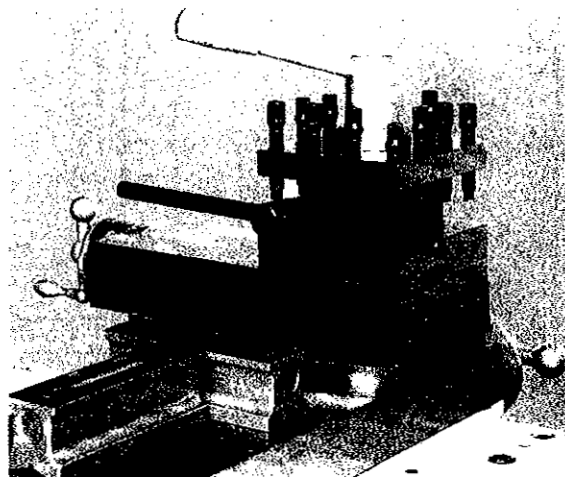
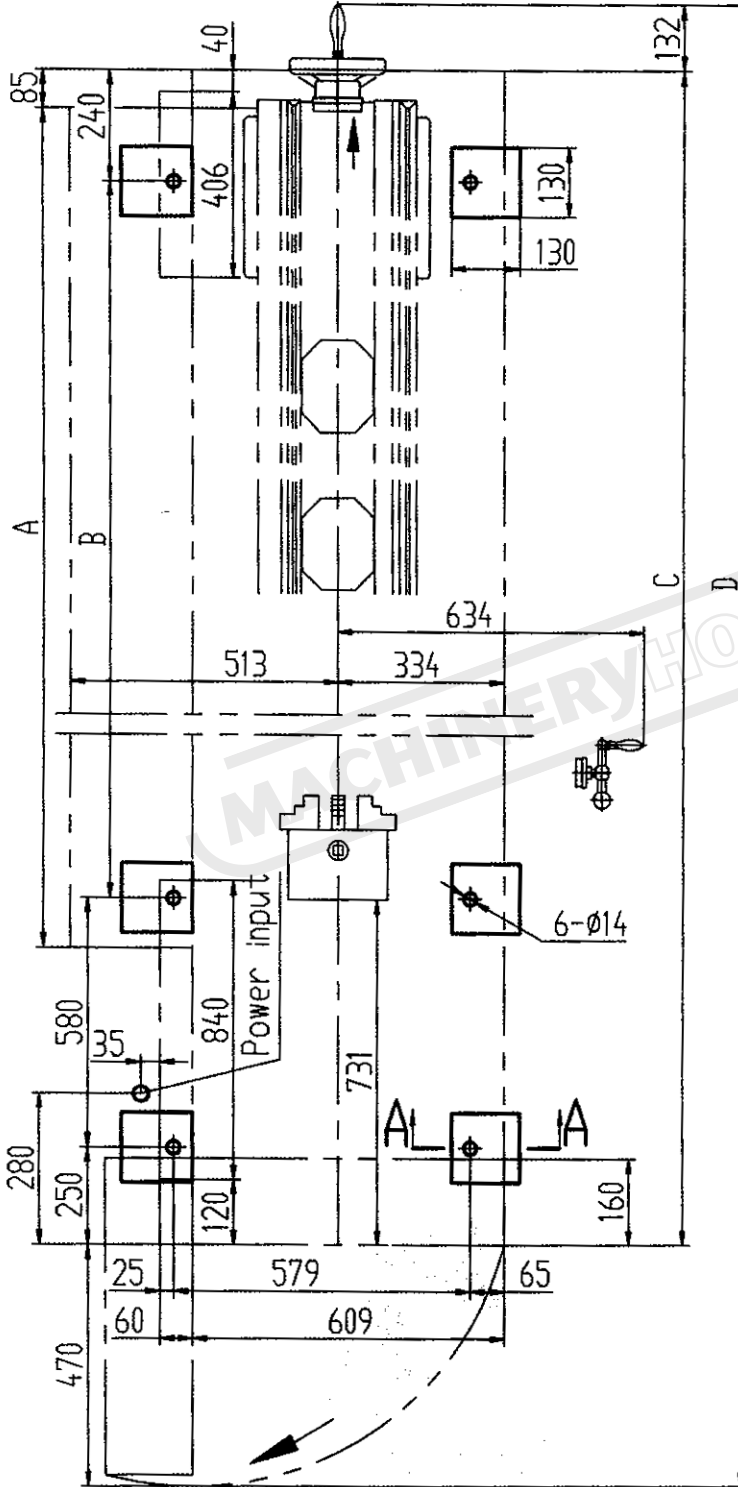

illustration 2-3

C6251A, C6256A LAY-OUT AND FIXING DIAGRAMS

Limit position of tailstock



Limit position of change gear cover

	A	B	C	D
distance between centers 1000mm	1665	1296	2366	2968
distance between centers 1500mm	2105	1746	2816	3418
distance between centers 2000mm	2605	2246	3316	3918

illustration 2-3

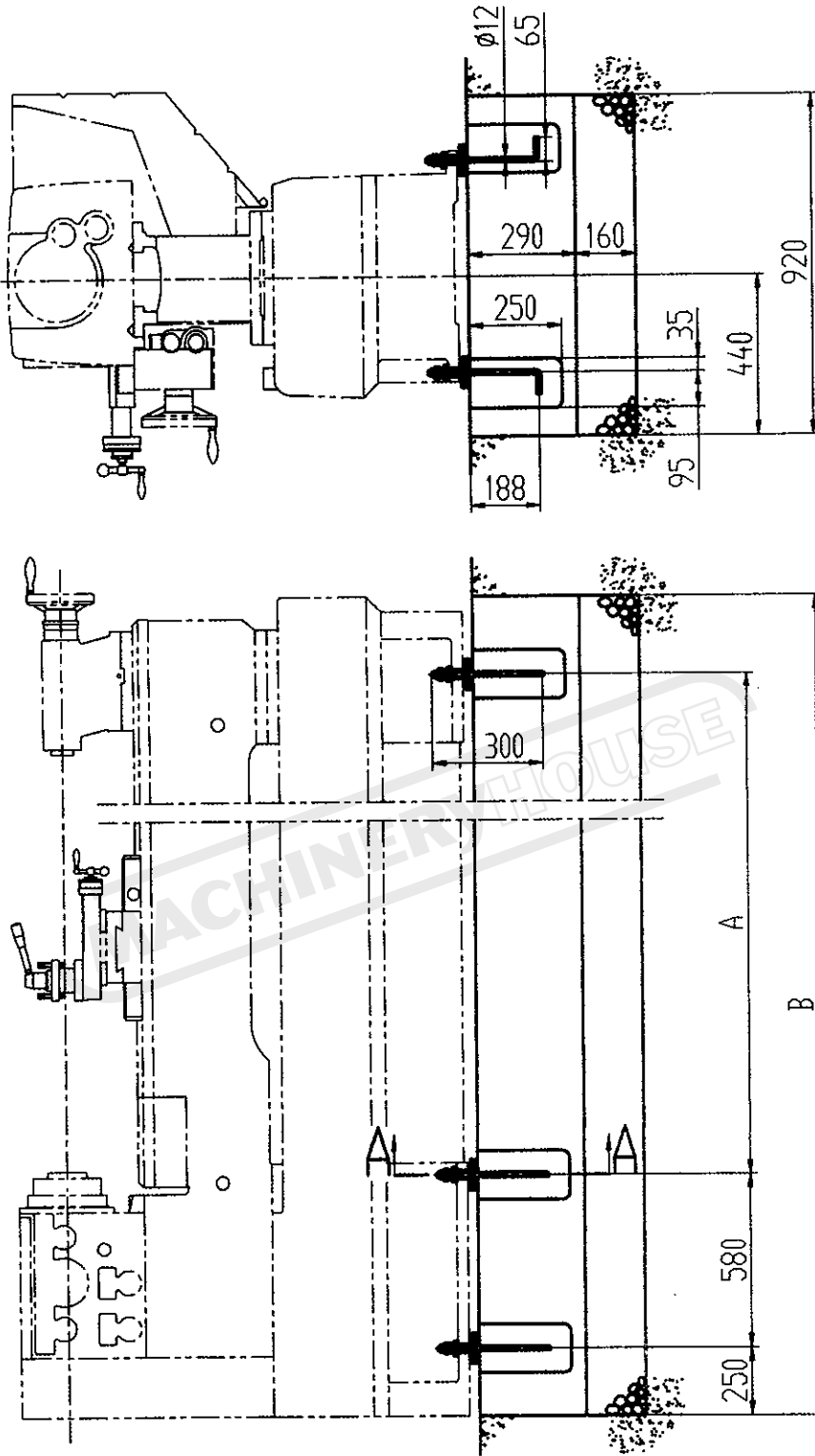

	distance between centers 1000mm	distance between centers 1500mm	distance between centers 2000mm
A	1296	1746	2246
B	1796	2816	3316

illustration 2-3

C6251A, C6256A LAY-OUT AND FIXING DIAGRAMS

Limit position of tailstock

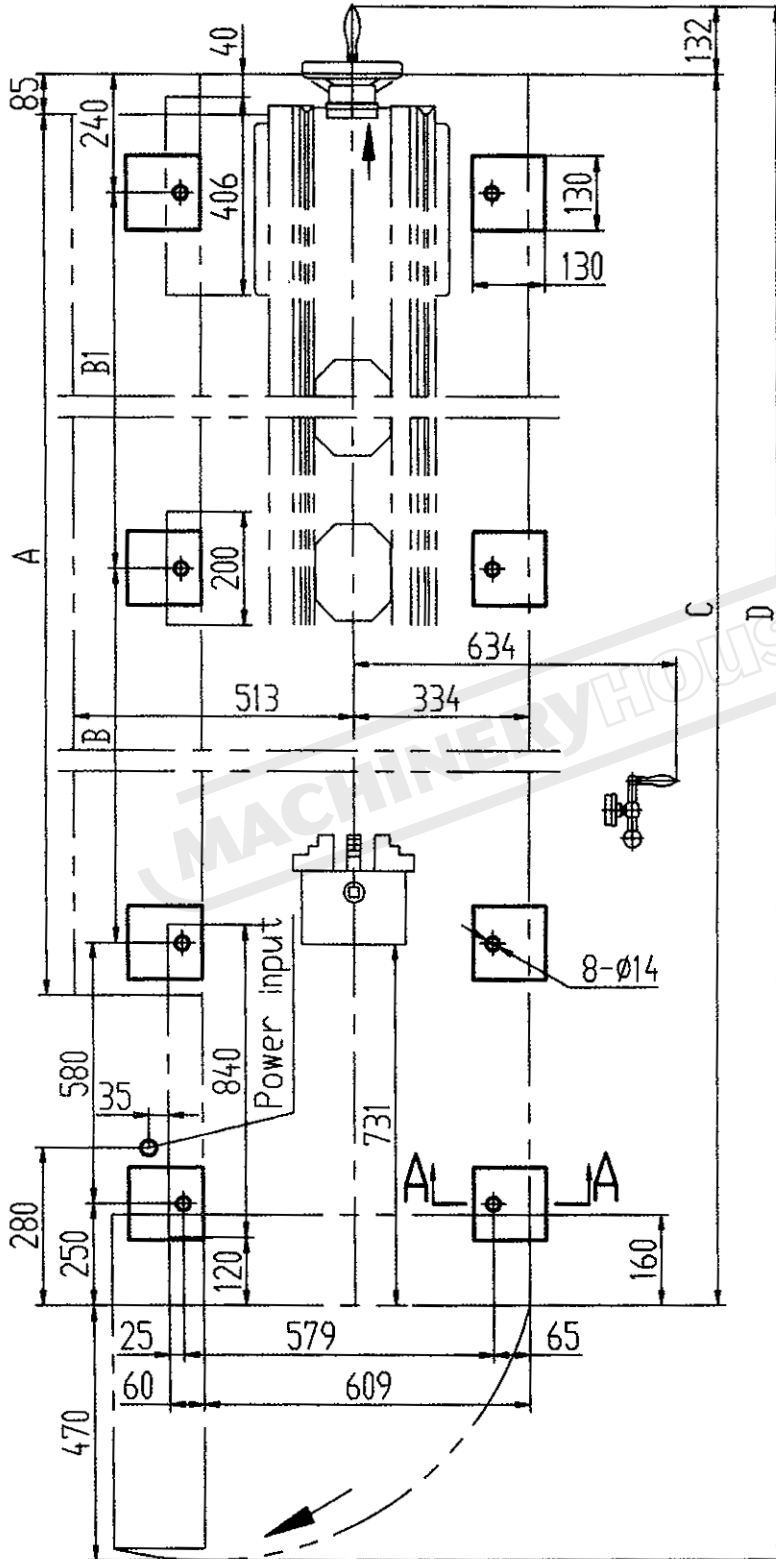

Limit position of change gear cover

	A	B	B1	C	D
	3605	1606	1640	4316	4918
distance between centers 3000mm					

illustration 2-3

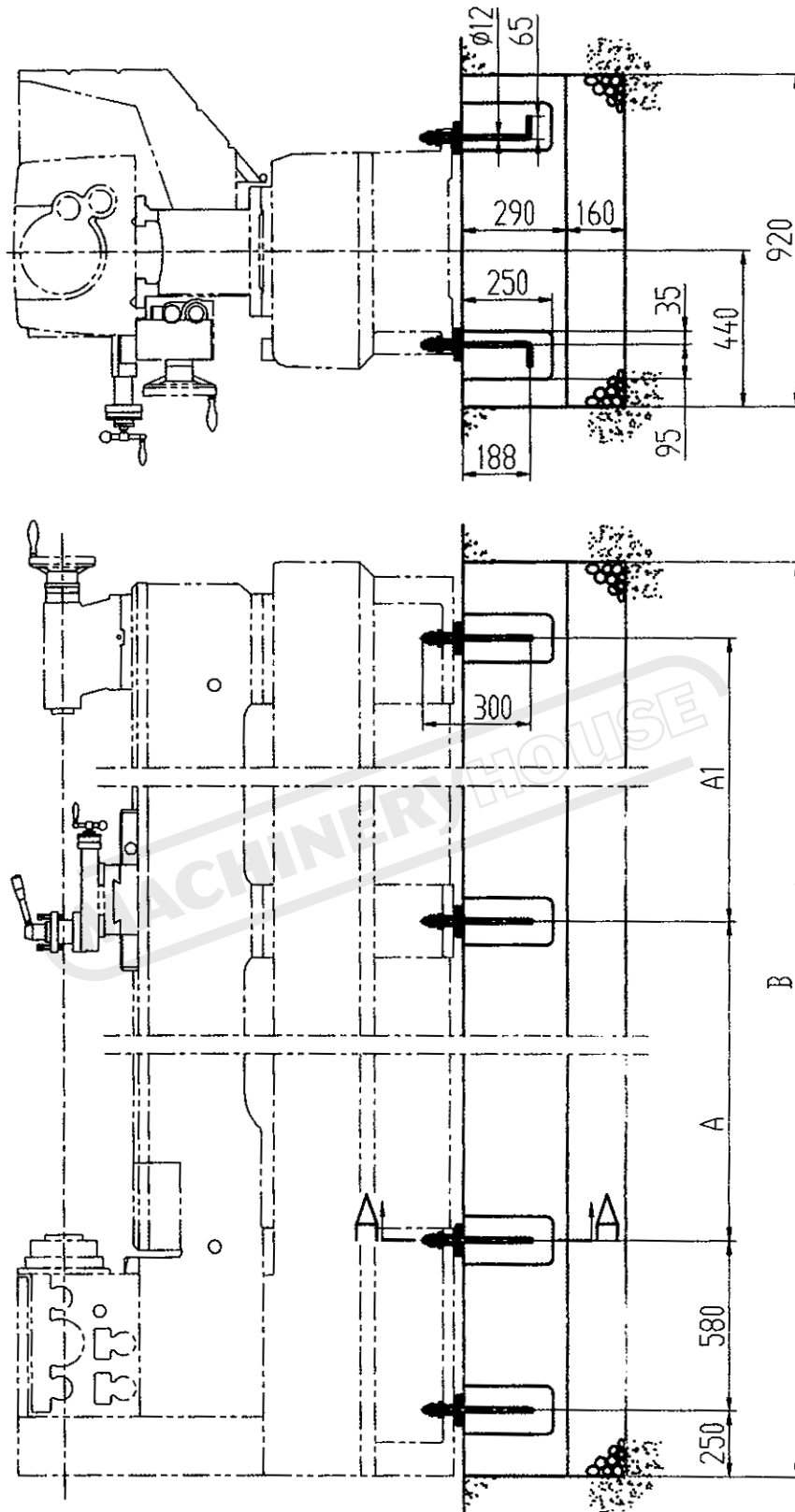

	A	A1	B
distance between centers 3000mm	1606	1640	4316

3. Electric Circuit Control

3-1 Electric Wiring

You can find the electric control box by open the metal cover behind the lathe bed. Connect the terminals "R", "S" and "T" to power source. Note that the specification of the electric wires must be above 8 sq. mm of its cross section area. Power switch of the machine and power source should be with fuse and the machine ought to be grounded.

3-2 Electric Device

1) The electric pannel is equipped with cut-off device and solenoid contactor for avoiding from overloaded breakdown of motor.

2) Tumbler Rotation Switch connect with Micro Switch.

3) Foot brake is connected with micro switch, braking prior to the manually starting. Whenever you release the foot brake, you need to re-operate Spindle Control Lever again to resume the operation of main spindle.

4) On top of the control box, there exist a "INTREMITENT" button for intermittent operation of the spindle.

3-3 Important Notes

**Check the rotating direction of spindle after wiring:

1. Turn on the power switch.
2. Slightly push "INTREMITENT" button.
3. Look at the rotating direction of Main Spindle from Tailstock.
4. If it is of anti-clockwise, you've got a right wiring.
5. If oppositely, exchange any of two wires among "R" "S" "T" terminals.

**If the power indicating lamp is on but you can not start the motor. Thus, it is overloaded.

If it happens the current out of limit, the cut-off device will activate immediately. In this moment, please turn off the power then press slightly the recovery plate near cut-off device in the control box. It will work again. (electric circuit program as illustrated on next page)

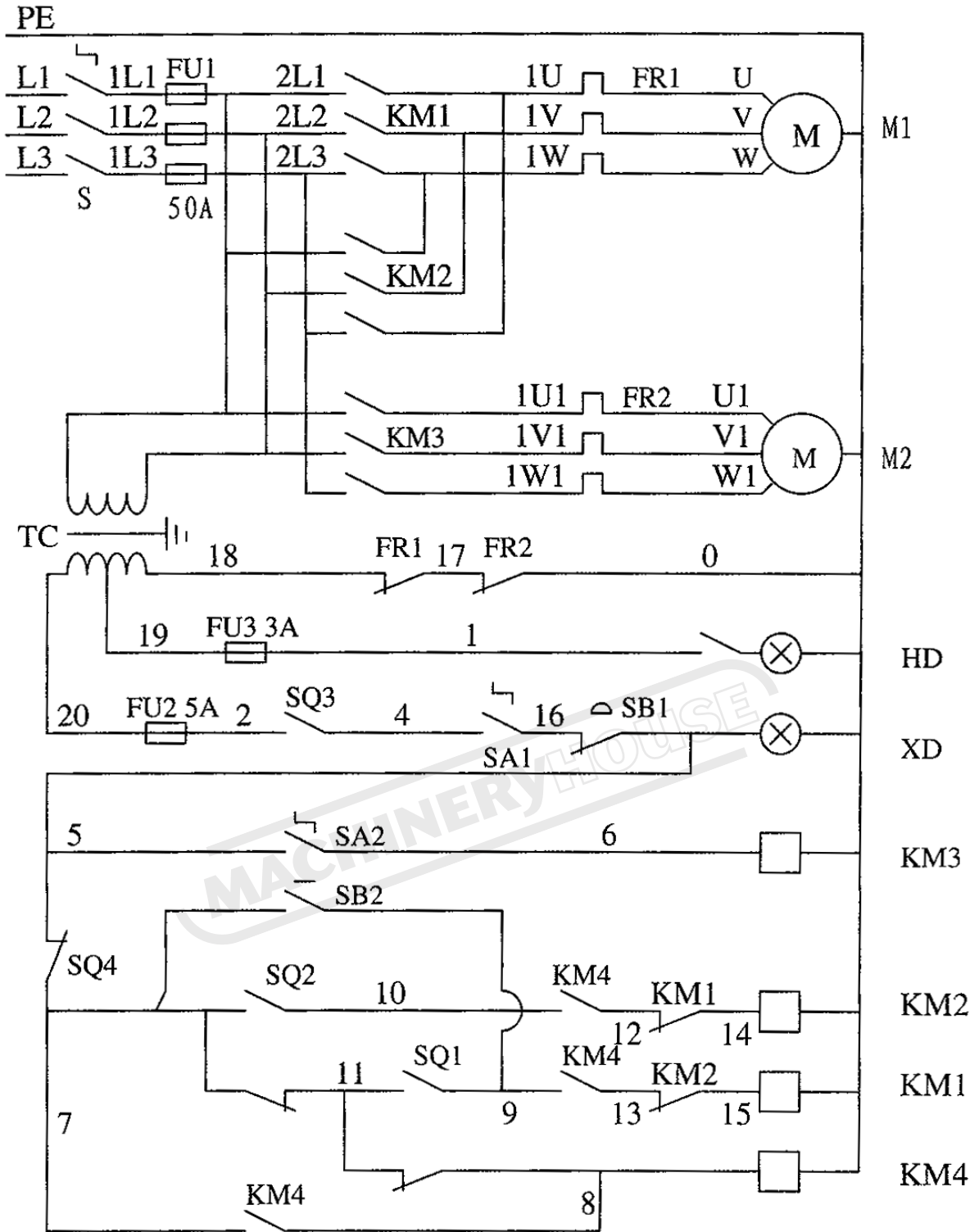

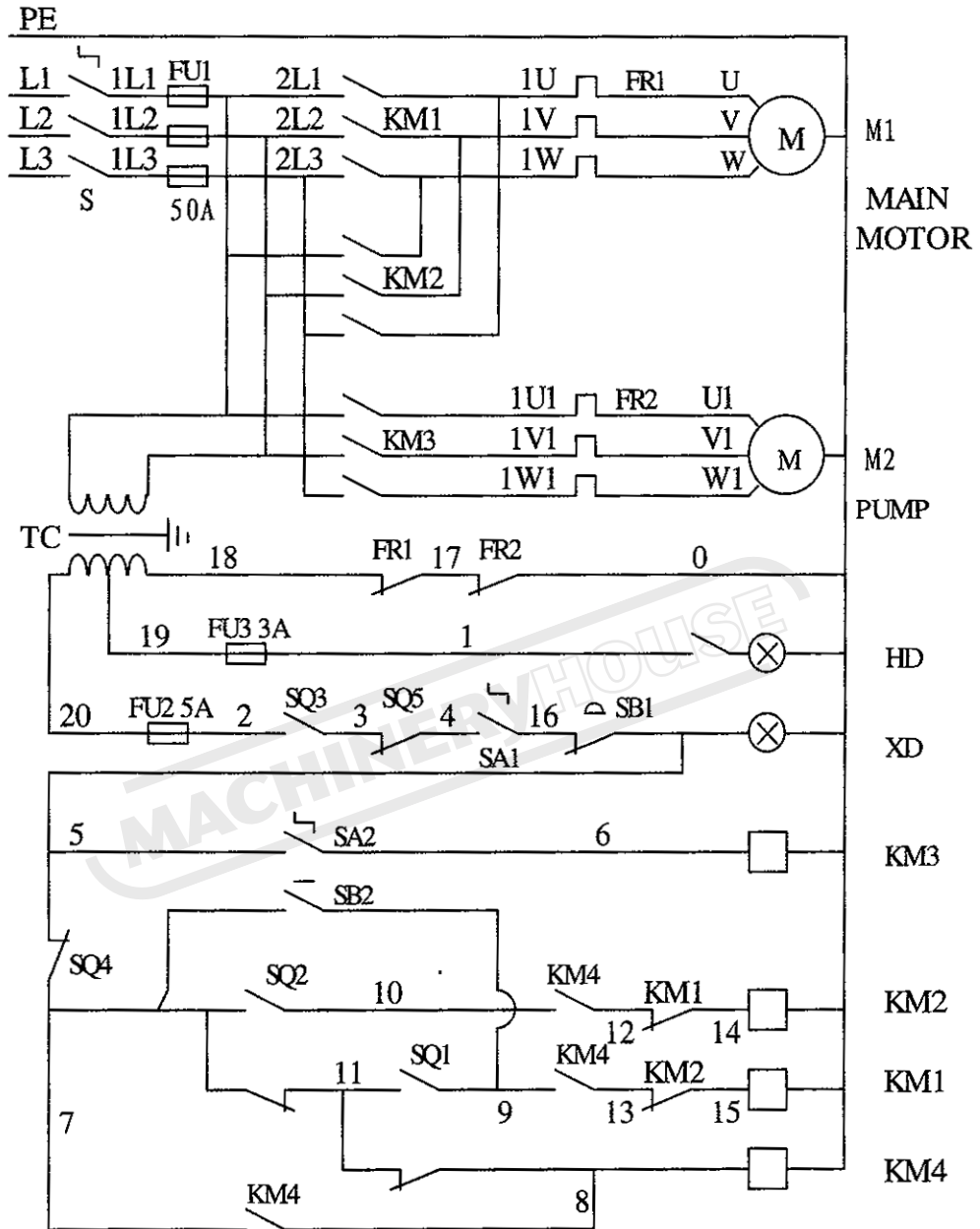



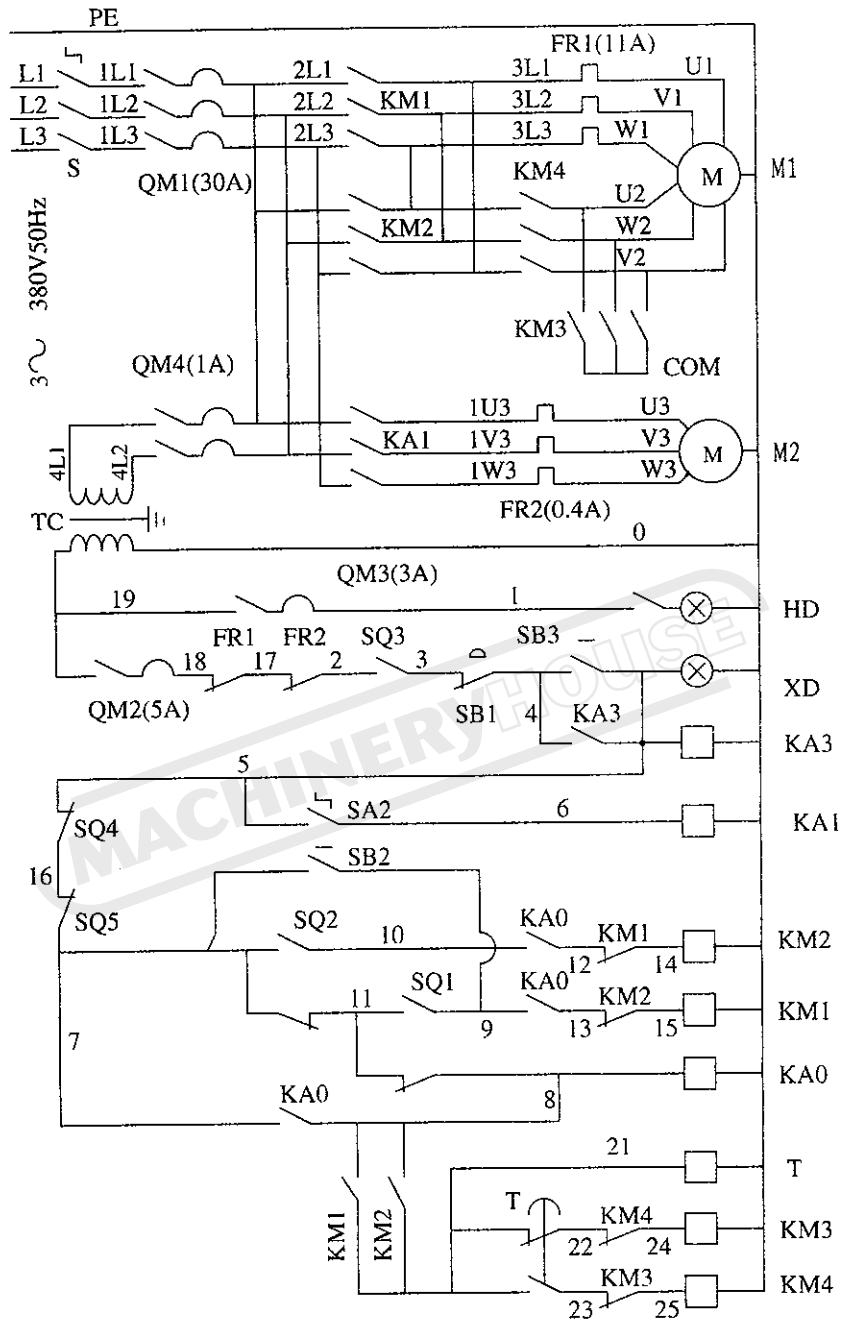









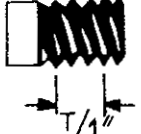

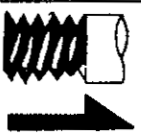



WIRINGDIAGRAM

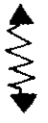

4. Test Running

4-1 Operation Symbols

1		High speed revolution	11		Variable adjustment (pressure)(clock - wise-pressure in- creased; counterclock- wise pressure decreased)
2		Low speed revolution	12		Electrical control box
3		Forward revolution	13		Imperial threads
4		Neutral gear	14		Metric threads
5		Reverse revolution	15		Auto feeding rate per revolution
6		Light	16		Pump
7		Intermittent button	17		Power switch- ON
8		Cross feeding	18		Power switch- OFF
9		Longitudinal feeding	19		Oil inlet (hole)
10		Cone clutch	20		

4-2 Transmissions and Stop of Main Spindle

You can start test run when you follow the previous steps as illustrated by the Manual. Position the High/Low Speed Lever (2) in "L", Main Spindle Speed Change Lever (3) in left position, Forward / Reverse Lever (4) in the middle of "N" position. Turn Start Lever (11) Right and push down to rotate obversely the spindle; pull up to rotate reversely. By using Spindle Control Lever to operate the machine in normal condition, use brake when it needs to stop in emergency. Naturally, in this case, you need to push the Spindle Control Lever again in the middle position to re-start the Spindle.

Turn on Pump switch (10) to start pump. Adjust Valve (33) is used for adjusting the required quantity of cooling water.

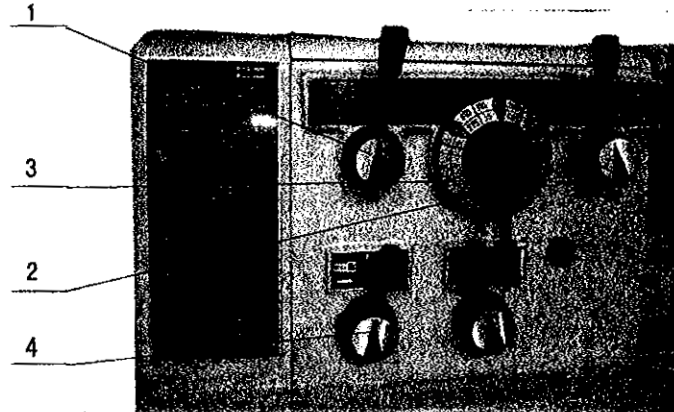

4 - 2

4-3 Selecting Main Spindle Speed

The speed of main spindle is consisted of 3 speed change lever, i.e. Speed Change Lever (1), High/Low Speed Lever (2) and Main spindle Speed Select Lever (3) to perform 12 speed change. When you shift High/Low Speed Lever (2) to the neutral position in between "H" and "L", you can rotate the Main Spindle only with you hands. For the safely reason and not to injure the gear every speed change must operate in the time while motor stops. If the teeth of the gear can not be properly engaged, push "INTERMITENT" button (9) then shift Speed Change Lever (1)(2) or (3) to change the rotating speed.

4 - 3

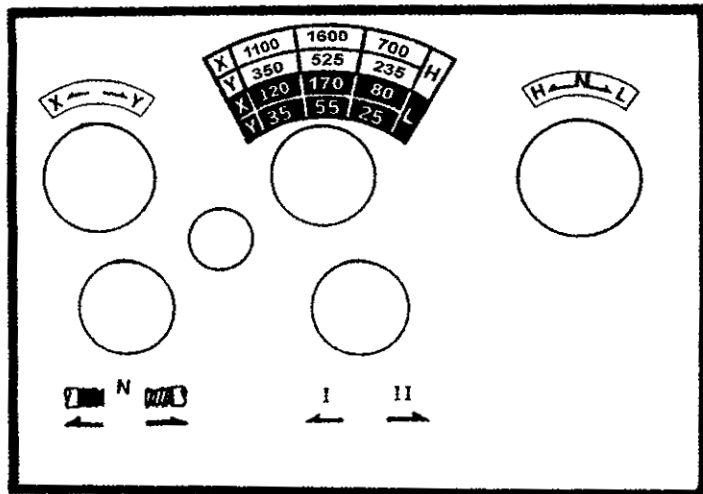

**CAUTION: DO NOT CHANGE SPEED WHILE SPINDLE IS RUNNING.
BE SURE ALL GEARS ARE PROPERLY ENGAGED BEFORE STARTING.**

4-4 “INTERMITTENT” Operation of Main Spindle

For the convenient way of changing Main Spindle Speed, confirming Feed Speed and Centering objects, the machine equipped with “INTERMITTANT” button (9) located in the right side of Gear Box. Push it down, Main Spindle will immediately rotate forward; and if to release the button, it stops. Note that the intermittent function cannot rotate reversely.

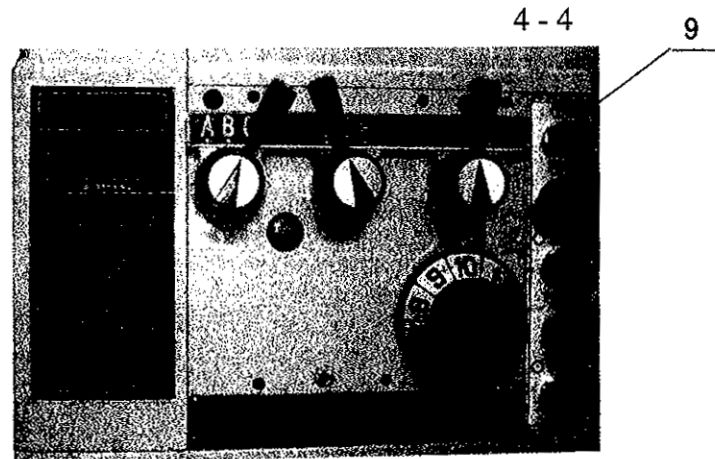

4-5 The Importance and Methods of Spindle Leveling Adjustment

1) Switch on to make the Spindle turn while the Spindle is set up at 1330 r.p.m. By putting the palm of the left hand on the Headstock cover to feel its chatter. An unlevelling Spindle will lead to lathe chatter. Move Leveling Block (either “A” or “B”) left or right to adjust until your left hand feels the minimum chatter.

2) Afterwards, change the Spindle speed to 2000 r.p.m. or 900 r.p.m. and check the Leveling with the same way as we did at 1330 r.p.m. by adjusting the Leveling Block “A” or “B”.

4 - 5

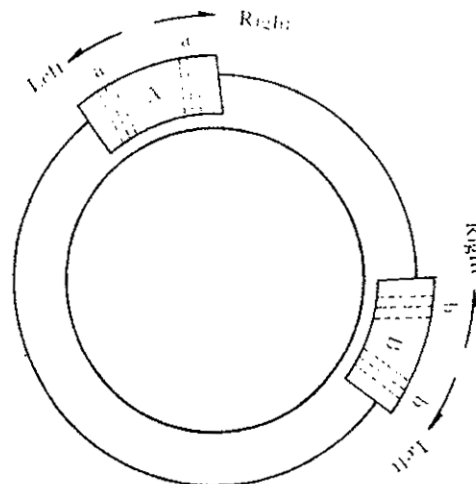

4-6 Transmissions and Stop of Gear Box

Open the end side cover of Headstock, you will find a gear train transmit the power from Headstock to Gear Box. Shift Forward/Reverse Lever (4) to right side, it runs forward, or to left side, reversely, or it stops if you shift it to the middle position. Never change speed while machine is running.

4-7 Operation of Gear Box

1. Cutting Threads

A special designed gearbox, you need not to use back gears to proceed threading. Please refer to gearbox cutting feed table and shift to appropriate Thread Feed Select Lever (5)(6)(7) respectively then you may obtain required specification.

2. Auto Feed

The selection of Auto Feed should be coordinated with the cutting speed and feed speed. Please refer to cutting table and select proper feed speed and follow the instruction plate to shift thread Feed Select Lever (5)(6)(7).

4-8 Manual Operations

Firstly shift the Half Nut Engaged Lever (18) of Apron and Forward/Reverse Lever (4) to "N" position, then you can arbitrarily operate Longitudinal Apron Hand-wheel (13) Cross Slide Handle (14) and Compound Rest Hand-wheel (32). It feeds 17mm per revolution of Apron Hand-wheel. The dial on Cross Slide and Compound Rest is graduated 0.02mm per division and feeds 4mm per revolution.

Release Tool Post Clamping Lever (36) and you can revolve the Tool Post anticlockwise then fix it. In order to lock the Apron, only screw up the Saddle Set Screw (20). If there is any backlash in between Cross Slide and Compound Rest, just to screw up the set screws on the both ends of the sloping plate.

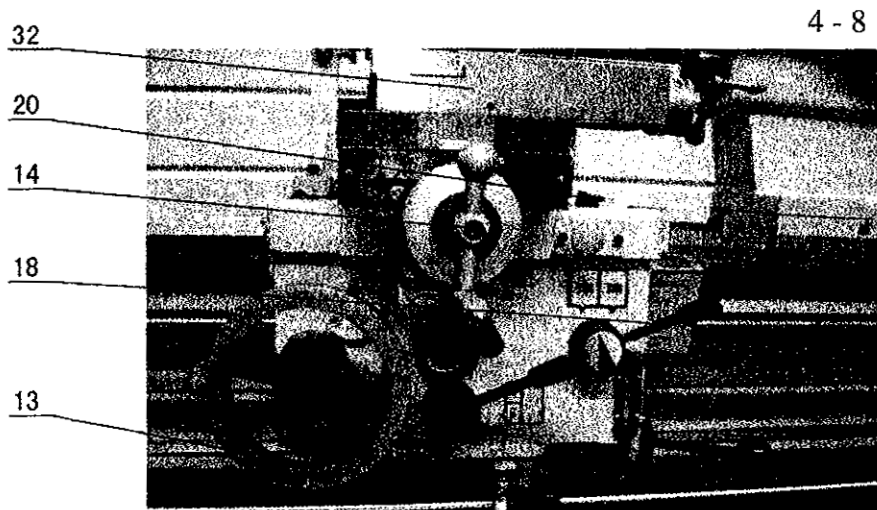

4-9 Auto Feed Operation

- 1) Shift Forward/Reverse Change Lever (4) on Headstock to decided the direction of feeding.
- 2) Select proper Feed Speed by shifting Gear Box Feed Change Lever.
- 3) Push down Half Nut Engaged Lever (18) to proceed threading.
- 4) Push down Longitudinal Feed Select Lever (19) when it needs to feed the tools crosswise.
- 5) Pull up Cross Feed Select Lever (19) when it needs to feed longitudinally.

4-10 Auto Feed Stop Operation

The machine is equipped with Auto Stop Feed in Apron. Screw up the screw on Eccentric Centering Ring (12) and settle in appropriate position. Note that the highest point of Eccentric Centering Ring have to be outward, and no mater it feed forward or backward, you can both set the Eccentric Centering Ring in required position. Test once before beginning to process in preventing to process in preventing unnecessary damage or danger.

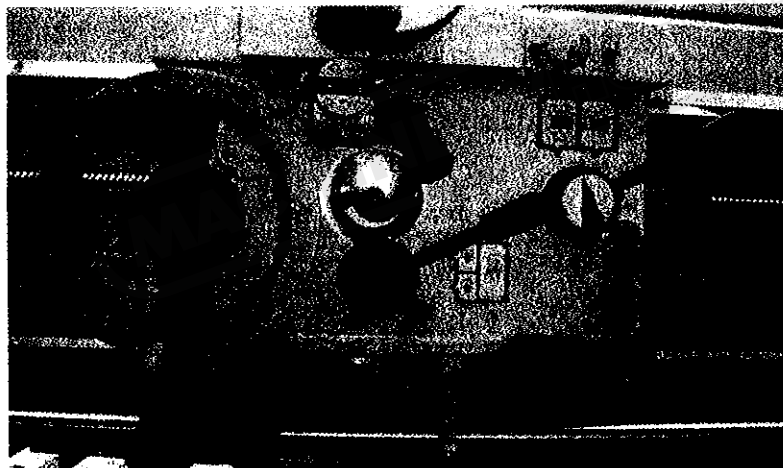

4-11 Four Position Auto Feed Stop Operation

If it requires processing the object to a certain length or object with steps, you may use this utility to complete a multi-section cutting.

- 1) Place Eccentric Centering ring (12) to any require position, the highest point indicates outward. Then fix it. Now you can try to operate Auto Feed of Apron to make sure precisely position by adjusting Eccentric Centering Ring.
- 2) Secondly, turn Auto Centering Lever to second point. Fix second Eccentric Centering Ring as per above method.
- 3) Same way to fix the third, the fourth.
- 4) While Apron is auto feeding forward, only the one Eccentric Centering Ring which

with its highest point outward can touch the Auto Stop Centering (15) and stops Apron Feed, it will pass through all the rest of Eccentric Centering Rings and will not activate at all.

4-12 Tailstock Operation

- 1) Tailstock Hand-wheel Dial is divided 0.02mm per graduation. Tailstock Hand-wheel (28) revolves one cycle clockwise, the quill of Tailstock feeds 5mm. If revolves anti-clockwise, the quill runs backward; when it runs to the last the center will be automatically telecasted.
- 2) By pushing the Tailstock Locking Lever (30) forward, you can steady the quill of Tailstock. If you wish to steady the Tailstock or the lathe bed you only need to push Tailstock Clamping Lever forward.
- 3) Tailstock Centering
Let loose of the Adjustment Screw (26) of Tailstock, then adjust the other side, tighten screws on both sides after adjustment.

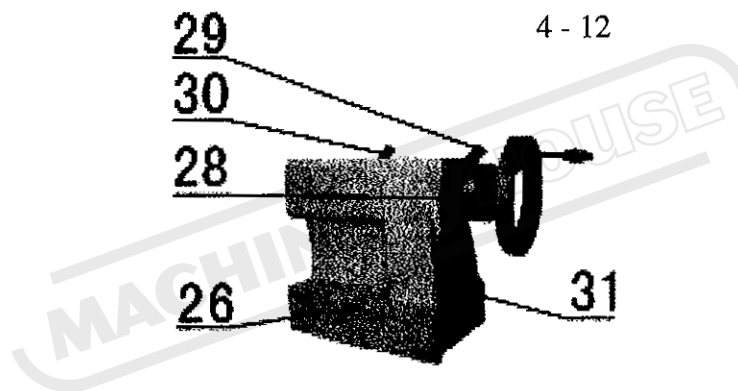

5. Cutting Threads

5-1 Lead Screw Dive

Forward Reverse shifting Lever (4) to right side. Lead screw(24) reversely to left side. Lead screw obverse to "N" position, thus, lead screw will not be rotated.



5-2 Cutting Thread

- 1) As soon as you decide to process which threads, Please position Thread Feed Select Lever (5) Thread Feed Change Lever (6) and 10 steps Feed Change Disc (7) in reference to the Thread Table.
- 2) Turn on the power, drive Lead screw directly.
- 3) Push down Half Nut Engaged Lever (18) and start screw cutting.

5-3 Thread Dial Indicator

- 1) To use Inch Lead screw in processing Imperial Threads.



To precede screw cutting in Imperial Threads, firstly you have to loose Half Nut then to match Half Nut as per instruction of Thread Dial indicator with no necessary to change Lead screw. When you do this procedure of threading, lock the index disc on shaft (1) than take 16T worm gear so that you can process all Imperial threads; that is, you have to follow the indicating plate and not to loose Half Nut while cutting Metric threads.

INDICATOR TABLE		
		
4½ , 11½ 13½ , 23	16	2
5 , 7 9 , 11 3 , 19 26 , 27		4
OTHER EVEN NUMBER THREADS		8

2) To use Metric lead screw in processing Metric Threads

Use 11T worm gear to cut 2.75 and 5.5, but if you wish to repeatedly use Half Nut, it requires to steady it on an original fix scale. For instant, the original point shows scale 1 in index disc when next clutching you must be start it when it also indicates scale 1 for not to damage the threads. Same story, if it is on scale 5, you should also have it on scale 5 in next coming clutching.

Use 14T worm gear for cutting 0.5 and 0.75 and when you repeatedly use Half Nut you don't have to fit it on certain scale. It can be done without any damage on threads in any scales of index disc.

INDICATOR TABLE			
			
11T	2.75	5.5	1
13T	3.25	6.5	
14T	1.75	3.5	1~7
	7		
	0.5	0.75	
	1	1.5	
	2	3	
15T	4	6	
	1.25	2.5	
	5		
18T	2.25	4.5	
	6.75		

5-4 Thread and Feed Table

C6251A, C6256A (Metric)

LEAD SCREW		P=6 mm											
CROSS FEED ROD		P=4 mm											
<p>(V)</p>		<p>(W)</p>											
<p>mm</p>	LEVER	1	2	3	4	5	6	7	8	9	10		
	II CFS	0.2			0.25				0.3			0.35	
	II CES	0.4	0.45		0.5	0.55			0.6	0.65		0.7	
	II CFU								0.75				
	I CFS	0.8	0.9						1.2			1.4	
	II CEU	1			1.25				1.5			1.75	
	I CFU	2	2.25		2.5	2.75			3	3.25		3.5	
	I CEU	4	4.5	4.75	5	5.5	5.75		6	6.5	6.75	7	
	I CDU	8	9	9.5	10	11	11.5	12	13	13.5	14		
	<p>T/1</p>	II ADR	64	72	76	80	88	92	96	104	108	112	
II AER		32	36	38	40	44	46	48	52	54	56		
II BER		16	18	19	20	22	23	24	26	27	28		
I AER		8	9	9 1/2	10	11	11 1/2	12	13	13 1/2	14		
I AFR		4	4 1/2	4 3/4	5	5 1/2	5 3/4	6	6 1/2	6 3/4	7		
I BFR		2	2 1/4	2 3/8	2 1/2	2 3/4	2 7/8	3	3 1/4	3 3/8	3 1/2		
<p>MP</p>		II CFS	0.1							0.15			
		II CES	0.2			0.25				0.3		0.35	
		I CFS	0.4	0.45		0.5	0.55			0.6	0.65	0.7	
		II CEU								0.75			
	I CES	0.8	0.9						1.2		1.4		
	I CFU	1			1.25				1.5		1.75		
	I CEU	2	2.25		2.5	2.75			3	3.25	3.5		
	I CDU	4	4.5	4.75	5	5.5	5.75		6	6.5	6.75	7	
	<p>DP</p>	II AER	64	72	76	80	88	92	96	104	108	112	
		II BER	32	36	38	40	44	46	48	52	54	56	
I AER		16	18	19	20	22	23	24	26	27	28		
I AFR		8	9	9 1/2	10	11	11 1/2	12	13	13 1/2	14		
I BFR		4	4 1/2	4 3/4	5	5 1/2	5 3/4	6	6 1/2	6 3/4	7		
<p>mm / O</p>		LEVER	1	2	4	5	7	8	10				
		II CFT	0.059	0.066	0.073	0.081	0.088	0.096	0.103				
		II CET	0.118	0.132	0.147	0.162	0.176	0.191	0.206				
		I CFT	0.235	0.265	0.294	0.323	0.353	0.382	0.411				
		I CET	0.470	0.529	0.588	0.647	0.705	0.764	0.823				
	I CDT	0.940	1.058	1.176	1.293	1.411	1.528	1.646					
	<p>mm / O</p>	II CFT	0.020	0.023	0.026	0.028	0.031	0.033	0.036				
		II CET	0.041	0.046	0.051	0.056	0.061	0.067	0.072				
		I CFT	0.082	0.092	0.102	0.113	0.123	0.133	0.143				
		I CET	0.164	0.184	0.205	0.225	0.246	0.266	0.287				
I CDT		0.327	0.368	0.409	0.450	0.491	0.532	0.573					

C6251A, C6256A (Inch)

LEAD SCREW 4. T. P. I
 CROSS FEED ROD 10. T. P. I

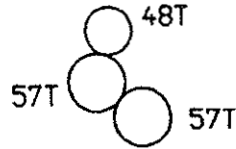

(V)

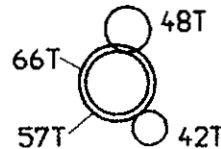

(W)

	LEVER	1	2	3	4	5	6	7	8	9	10
 mm	II CFS	0.2			0.25			0.3			0.35
	II CES	0.4	0.45		0.5	0.55		0.6	0.65		0.7
	II CFU							0.75			
	I CFS	0.8	0.9					1.2			1.4
	II CEU	1			1.25			1.5			1.75
	I CFU	2	2.25		2.5	2.75		3	3.25		3.5
	I CEU	4	4.5	4.75	5	5.5	5.75	6	6.5	6.75	7
	I CDU	8	9	9.5	10	11	11.5	12	13	13.5	14
	II ADR	64	72	76	80	88	92	96	104	108	112
	II AER	32	36	38	40	44	46	48	52	54	56
II BER	16	18	19	20	22	23	24	26	27	28	
I AER	8	9	9 1/2	10	11	11 1/2	12	13	13 1/2	14	
I AFR	4	4 1/2	4 3/4	5	5 1/2	5 3/4	6	6 1/2	6 3/4	7	
I BFR	2	2 1/4	2 3/8	2 1/2	2 3/4	2 7/8	3	3 1/4	3 3/8	3 1/2	
 MP	II CFS	0.1						0.15			
	II CES	0.2			0.25			0.3			0.35
	I CFS	0.4	0.45		0.5	0.55		0.6	0.65		0.7
	II CEU							0.75			
	I CES	0.8	0.9					1.2			1.4
	I CFU	1			1.25			1.5			1.75
	I CEU	2	2.25		2.5	2.75		3	3.25		3.5
	I CDU	4	4.5	4.75	5	5.5	5.75	6	6.5	6.75	7
	II AER	64	72	76	80	88	92	96	104	108	112
	II BER	32	36	38	40	44	46	48	52	54	56
I AER	16	18	19	20	22	23	24	26	27	28	
I AFR	8	9	9 1/2	10	11	11 1/2	12	13	13 1/2	14	
I BFR	4	4 1/2	4 3/4	5	5 1/2	5 3/4	6	6 1/2	6 3/4	7	
 DP	LEVER	1	2	4	5	7	8	10			
	II CFT	0.0022	0.0025	0.0027	0.0030	0.0033	0.0036	0.0038			
	II CET	0.0044	0.0049	0.0055	0.0060	0.0066	0.0071	0.0077			
	I CFT	0.0087	0.0098	0.0109	0.0120	0.0131	0.0142	0.0153			
	I CET	0.0175	0.0197	0.0219	0.0241	0.0262	0.0284	0.0306			
	I CDT	0.0350	0.0394	0.0437	0.0481	0.0525	0.0569	0.0612			
	II CFT	0.00048	0.00054	0.00060	0.00066	0.00073	0.00079	0.00085			
	II CET	0.00097	0.00109	0.00121	0.00133	0.00145	0.00157	0.00169			
	I CFT	0.00193	0.00218	0.00242	0.00266	0.00290	0.00314	0.00338			
	I CET	0.00387	0.00435	0.00484	0.00532	0.00580	0.00629	0.00677			
 in / °	I CDT	0.00774	0.00870	0.00967	0.01064	0.01160	0.01257	0.01354			

6. Lubrication

6-1 Lubrication in headstock

An oil-splash feed is utilized in the lubrication system of Headstock. On top of the Headstock there grooves surrounded providing lubricant flow into the spindle bearing along the groove, then finally flow down on the bottom of the box. When supplying the lubricant, remove the cap of oil sight glass. To drain the waste oils away, a drainer hole located in the right side downward of the Headstock.

Please take good care of checking whether the Headstock has been filled up with lubricant or not when you purchase the machine. If negative, use as show in the figure (6-4) lubricating oil. We request you to change the lubricant at first month and then do once every two months so to assure the gears are working in the best conditions.

6-2 Lubricating in Gear Box and Apron

- 1) Gear Box is oil-bath lubricated to insure the lifetime of gears and bearing. It is recommended the lubricant to be changed every six months.
- 2) Apron is also oil-bathed. If the oil quantity in Apron is lower than center level of oil sight glass, then it is time to add up some oil to standard level.

6-3 Useful Reference Lubricating Table for other Mechanism

No.	Location	How	How many	For how long to	Oil exchange time
1	Headstock	Remove the screws of filler hole on left side up	L	Once a month	One month, then every two month
2	Gear Box	Open top cover remove the screws of filler hole	L	Once a month	Every half year
3	Apron	Remove the screws of filler hole	L	everyday	
4	Compound Rest	By oilcan	approp.	everyday	
5	Auto Feed lever	By oilcan	approp.	everyday	
6	Tailstock	By oilcan	approp.	everyday	
7	Lead screw	By oilcan	approp.	everyday	
8	Bracket of Three Rods	Remove the screw of filler hole	approp.	everyday	
9	Bedway	Press the manual oil pump	approp.	everyday	

6-3 Add oil once a day

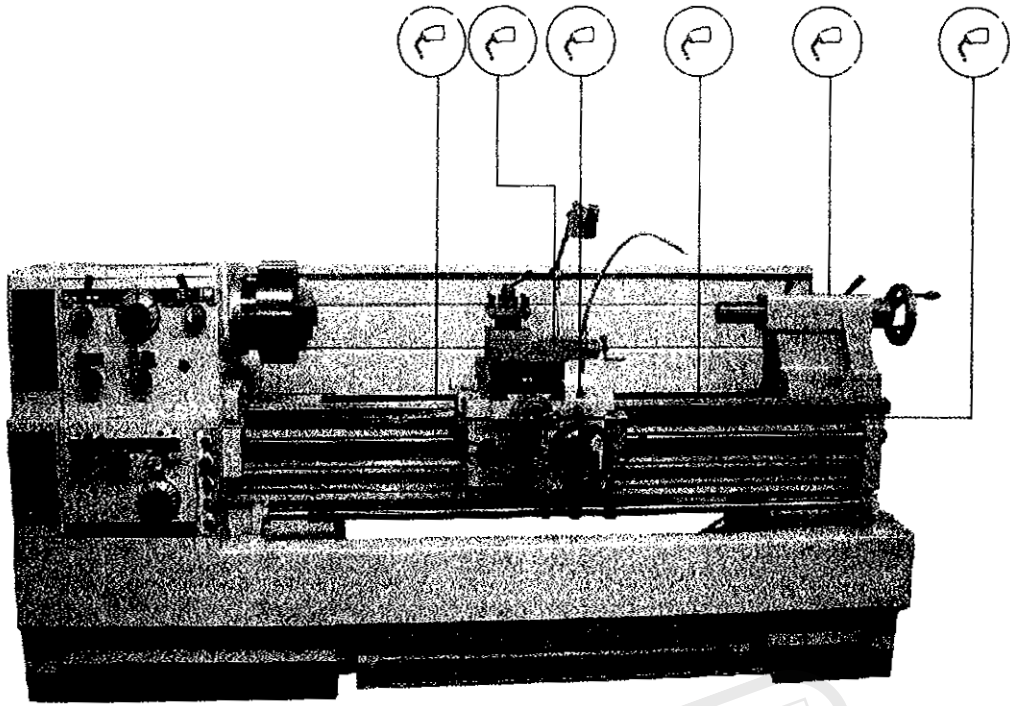

6-4 Lubrication Location

(A) Filler hole (B) Drainer hole

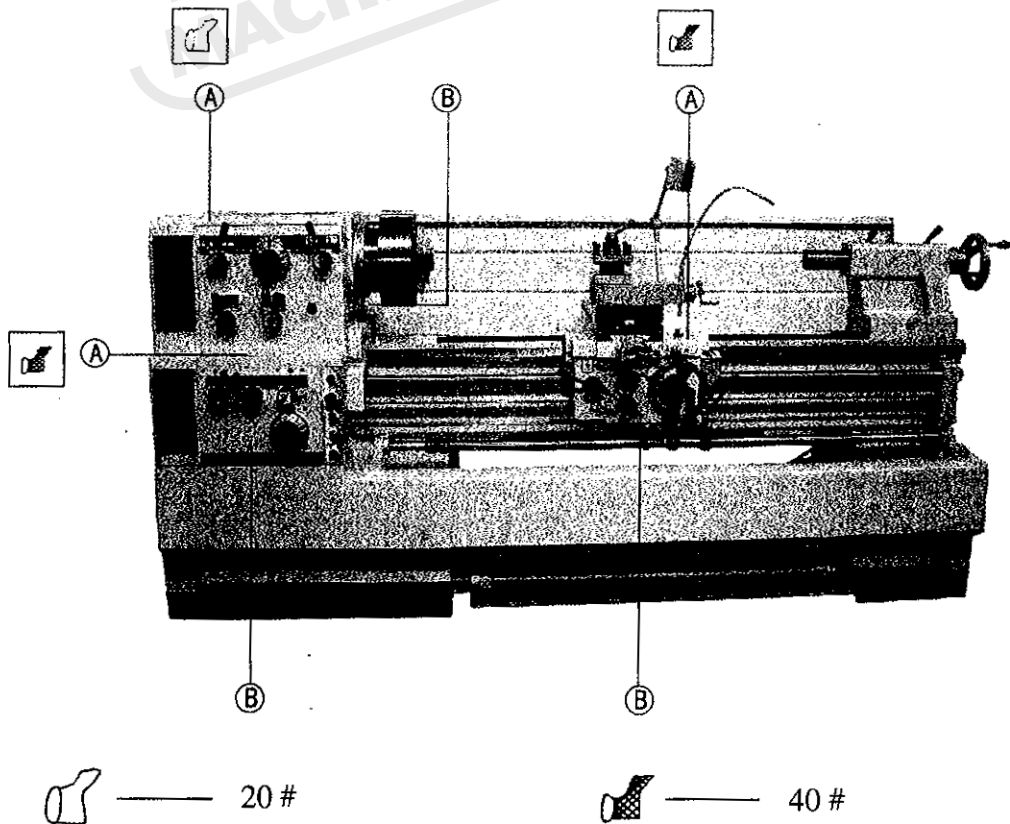

7. Maintenance & Servicing

For a better acknowledgement to this lathe, either in operation or some simple way of trouble-shooting or servicing, to bring the machine to the utmost function, we are now stating some important points as below.

7-1 Headstock

1) Prevent from oil leakage from top cover of Headstock:

Before covering the top cover of Headstock, whenever it is removed, please wipe to clean the contact surface and apply some grease on it. Make sure it is tightly securing by setscrews.

2) Prevent from blocking up the oil circuit:

The leakage of front headstock cover mostly caused by over-filling the oil or a block-up of oil circuit. In this moment, remove the Headstock cover first, then blow the air jet into two oil circuit hole, which is on up side and down side of front Spindle bearing, in the same time to rotate the Spindle and it will work again.

3) Adjustment on Spindle Bearing:

The front and the intermediate section of spindle roller bearing. For high accuracy and to meet the request of operation function, you may be asked to adjust the appropriate pressure on bearing. After a long period of operation, nut "G" probably will get loose and result the "wave trace" on cutting surface. You need to adjust it at this moment. Use a hexagon socket wrench to remove the setscrew and install back with the fixing nut again properly. Only an appropriate pressure is enough. Never have it too tight, as it will lead to the bearing to over-heated or damage the rolling surface of bearing and lessen its dynamics. Make sure to fix the setscrew completely after adjustment as illustrated.

illustration 7-1-3

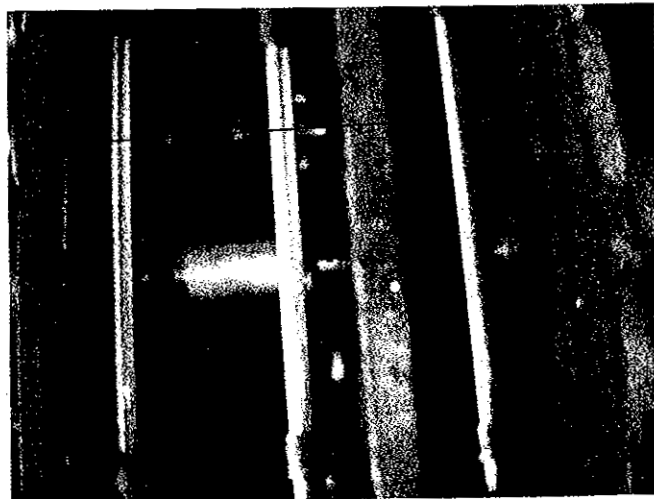

7-2 Apron & Saddle

1) Filler hole location of Apron:

On the right platform of Saddle. The filler hole has oil plug indicates "OIL".

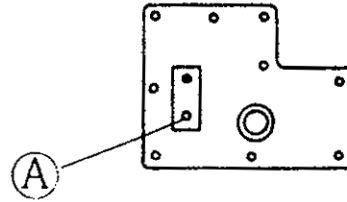

2) Drainer Hole location of Apron:

On the bottom cover of Apron, as illustrated left, position "A" (also can be seen in front side of Apron downward)

3) Model No of Apron lubricant & change period

Model No is way oil. ISO UG 68, suggestion changing period is every half a year.

4) Adjustment for the loosely Half Nut Engaged Lever:

After long period of operation, the Half Nut Engaged Lever will get loose, please adjust as per following steps:

- a. Remover Thread Dial Indicator, there is four adjustment screws can be seen.
- b. Adjust those four screws to proper pressure as soon as to push the lever.
- c. Install Thread Dial Indicator back.

5) Feed load adjustment (cross feed & longitudinal feed):

There is a conical clutch "D" in the middle of Apron which is an overload protector device. The capacity of safety load is about 12 kg. Appropriate load can be adjusted by a hexagon socket screw in the middle of apron. Turn clockwise to increase load; anti-clockwise it decrease. A proper load capacity can be tested by pressing hand-wheel handle while auto feed operates to see if it wills automatically cut-off when load is over 12 kg.

illustration 7-2-5

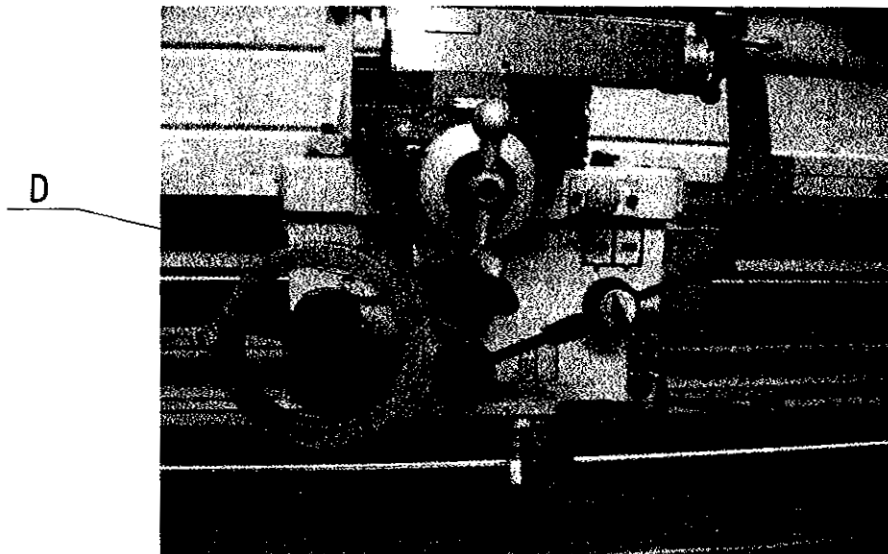

7-3 Gear Box

1) Filler hole location of Gear Box:

Under the top cover of gearbox, remove the top cover there is an oil plug indicates, "OIL" where filler hole is in. as per illustration "A".

2) Drainer hole location of Gear Box:

On the left side of the ten-step speed change the disc downward. The drainer hole is in the screws with hexagon socket nut as illustrated "B" where an arrow point.

3) Oil brand and oil exchange time:

We suggest as show in the figure 6-4 and please change it every half-year.

illustration 7-3

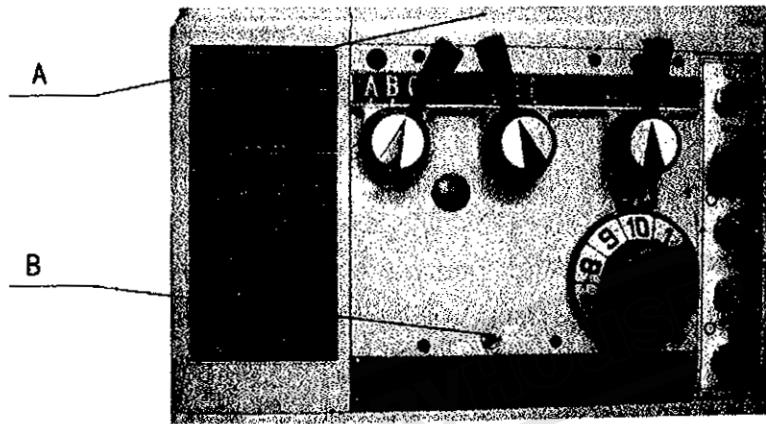

7-4 Adjustment of Tailstock Centering

- 1) To adjust the accuracy of Tailstock, get loose two hexagon socket screws which connect the Tailstock body and Bottom Plate, adjustment to be done depends on what you expect it to which direction; if you need it to be in cline front, you must let loose the adjustment screws then correct it to required accuracy minutely, then install the hexagon socket screws and the adjustment screws. Never have it too tight or the Clamping Lever will be come heavier, as per illustrated "A".

- 2) If you feel the Release Hand-wheel is still too heavy although the Tailstock quill has been fixed. This is because the Clamping Block cannot be released freely. You have to push forward the Clamping lever a bit and it will recover in good order again.

illustration 7-4

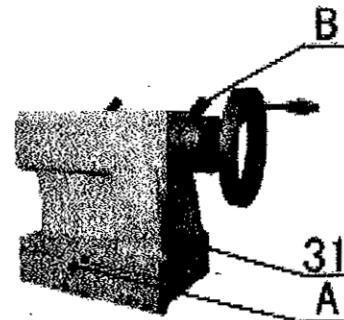

7-5 Belt Tension Adjustment

After long period of working, belts will get slacked, so you need to adjust it for some times. It is as:

- 1) Open the cover on rear left side of the lathe.
- 2) Release adjustment Nut "A", lower the motor to proper height and bring the belt to certain tension.
- 3) Install the Nut tightly.

illustration 7-5

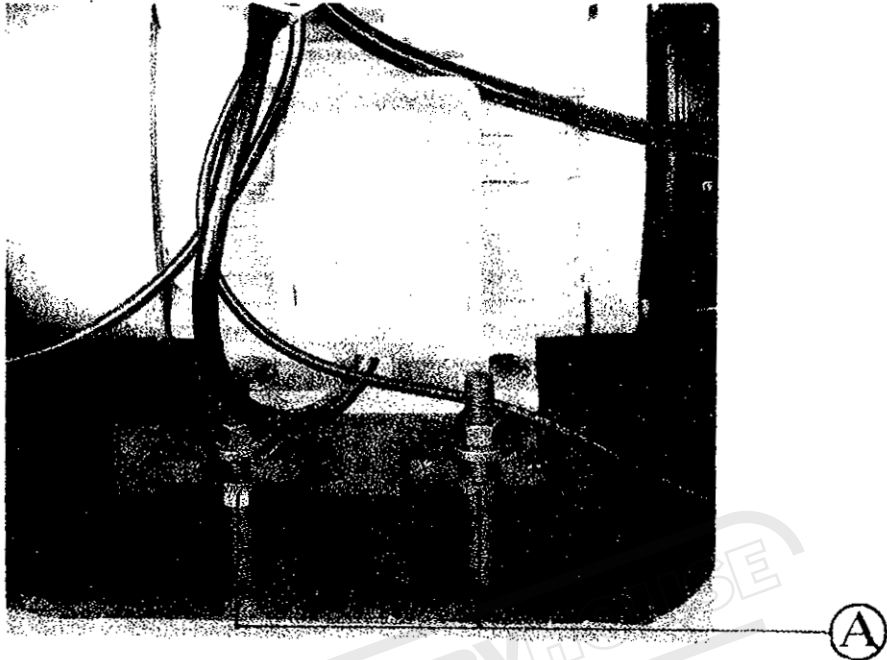

7-6 Foot Brake Belt Adjustment

A brake pad fading may caused the slack of brake belt. Adjust Nut "H" on brake belt. Open side rear cover, remove top nut, push bottom nut to appropriate position, then install two nuts to complete adjustment. Install the side rear cover.

illustration 7-6

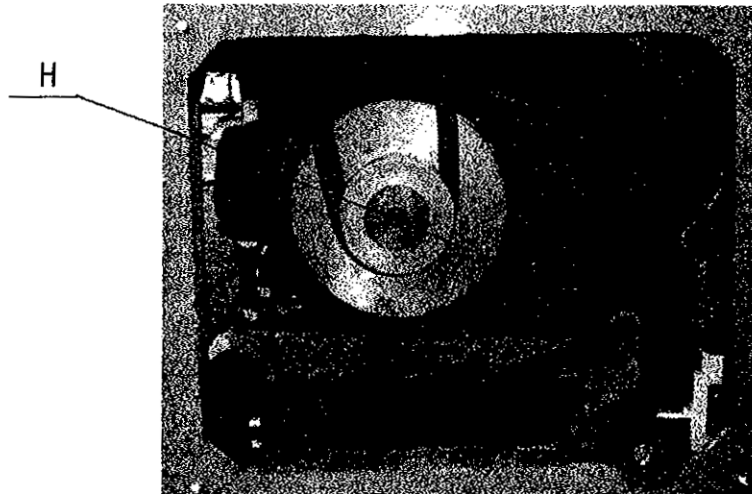

7-7 Brake and Micro Switch Adjustment

Foot brake is linked to Micro Switch. It needs to maintain a backlash of 3-5mm from Brake Cam to the touching head of the Micro Switch. Always disconnect the power to break the machine or it will cause the fading of brake pad. After stepping the foot brake, needs to reiterate the spindle control lever to make the spindle revolute again.

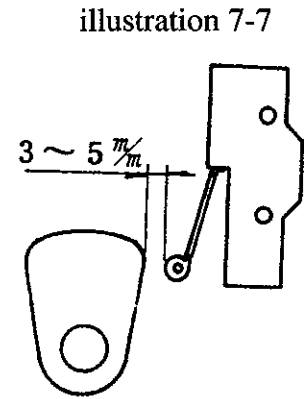

7-8 Adjustments to the Backlash of Lead screw

When it happens to some pile-up threads during processing, it is caused by the backlash on Lead screw. Adjust the packing nut appropriately on rear side of the Lead screw. Open the cover on rear side of Lead screw Bracket, turn nut "A" very tight with no backlash left behind. (To check the result by pushing down Half Nut Handle, turn Apron Hand-wheel to rotate, clasp the contact point between Gear Box and Lead screw. Make sure there is no backlash created). Install "A" nut and side cover.

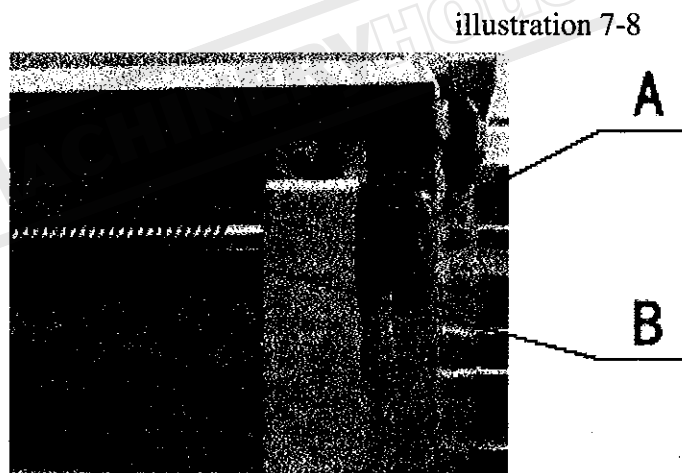

7-9 Maintenance for Cutting Liquid Coolant Pump

If there is no cutting liquid flow out when you start the motor switch, you have to check whether motor has activated or not, secondly to check whether the cutting liquid in tank is over the level, if not, needs to add more liquid. While re-starting the pump if you still can not see any liquid were pumped out, it must be some block-up in pump or leakage, and it has to be taken apart for servicing or cleaning.

8. Chucks and Chucks Mounting

When fitting chucks or faceplates, first ensure that spindle and chuck tapers are scrupulously clean and that all cams lock in the correct positions; see Fig. It may be necessary when mounting a new chuck to re-set the cam lock studs (A). To do this, remove the cap-head locking screws (B) and set each stud so that the scribed ring (C) is flush with the rear face of the chuck-with the slot lining up with the locking screw hole.

Now mount the chuck or faceplate on the spindle nose and tighten the six cams in turn. When fully tightened, the cam lock line on each cam should be between the two V marks on the spindle nose.

If any of the cams do not tighten fully within these limit marks, remove the chuck or faceplate and re-adjust the stud as indicated in the illustration. Fit and tighten the locking screw (B) at each stud before remounting the chuck for work. A reference mark should be made on each correctly fitted chuck or faceplate to coincide with the reference mark scribed in the spindle nose.

This will assist subsequent remounting. Do Not Interchange Chucks Or Face Plates Between Lathes Without Checking For Correct Cam Locking.

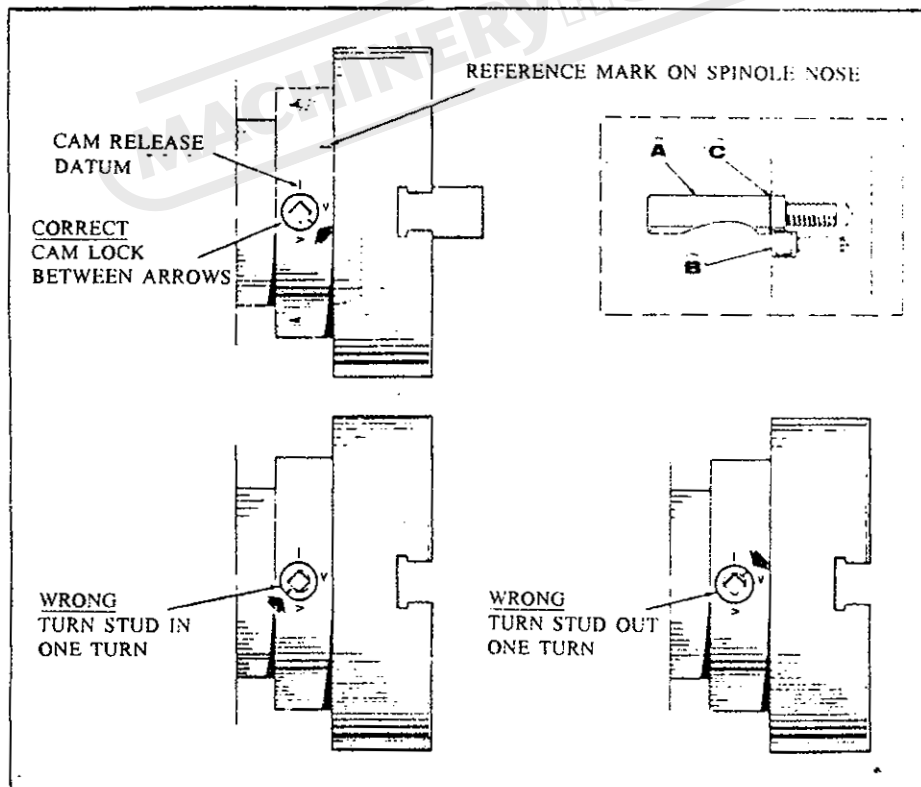

9. Preventive Maintenance

1. Daily Inspection:

Inspection of lathe is carried out on basis of each shift. The inspection work accords to the following item 1-1.

1-1 Check before start the motor.

- 1) Clean-up of machine: Dust, chips and other articles should be removed from sliding surface of machine to make the rotating or sliding parts performing easy and smoothly. All other static parts are often also cleaned to avoid the corrosion.
- 2) Gearing and oiling: Regular oiling should be done every day (see lubrication plan sheet) to keep the machine properly lubricated.
- 3) Check all the running parts not too tight, or loose. Bearings of headstock, longitudinal and cross feed, tool holders etc would be examined and adjusted by hand to proper fitness.
- 4) Check the sensitivity & reliability of all manual control levers:
To try the speed change rate function of headstock feeds and apron in gear box and inspect their starting, stopping and forward & reverse action whether they are sensitive and reliable or not.
- 5) Fixture and fig of headstock, tailstock and tool holder Tight clamping between tailstock and bed surface, close running fit of spindle in tailstock, clamp bolts of tool holder, and figs on headstock.

1-2 Check after start the motor.

- 1) To check electrical control system:
Try to put "on" and "off" button and examine the sensitiveness of starting, stopping and pilot lamp strictly.
- 2) The sensitivity and reliability of mechanical control device:
Control levers for forward and reverse main spindle, automatic feeds and threads change should be sensitive and reliable. Automatic control devices for longitudinal and cross feed, gear change threads change, carriage, and spindle direction change should be accurate also.
- 3) Limitation of noise and vibration:
When starting max speed of headstock spindle on no loading basis, check the noise and vibration whether they are over specified limit or not.
- 4) Coolant system:
Check the quantity of coolant oil and start the oil pump for inspecting its function and leakage.
- 5) Lubricating system:
Examine all Lubricating system carefully and ensure all flowing line without

obstacles.

1-3 Caution during operation:

1) Temperature of bearings.

Touch the main bearing by hand and feel the temperature is normally or not.

2) Temperature of motor:

Feel the temperature of motor bearing at the case of full load.

3) Noise and vibration:

If you find the noise and vibration of the machine are abnormal or irregular. Stop the machine immediately for inspection and adjustment.

4) Quality of products:

If you discover the quality of products is out of limit, stop the machine at once for finding the causes of defects.

5) Safety affairs:

- a. Must stop operation when you leave the machine.
- b. When changing main spindle speed or feeding speed stop running first.
- c. All tools and products are strictly not allowing to be left on sliding surface of bed.

1-4 Check after operation:

1) Cleaning and collection of all tools:

All tools should be kept clean first then put back to original position (tool cabinet).

2) Proper position of tailstock, carriage & tool holder:

Tailstock, carriage & tool holder should be placed to proper position.

3) Clean-up of machine:

All of the oily matters, chips etc, on the machine should be removed completely and put a thin lubricating oil on the sliding surface of machine to prevent the corrosion.

2. Weekly Inspection:

1) Lubricating system:

Clean up the whole lubricating system and replenish with fresh lubricating oil.

2) Cooling system:

Clean up the whole cooling system and replenish with new cooling oil.

3) Transmission system:

Check the damage of rubber V-belt and readjust the tensile strength of V-belt.

3. Monthly Inspection:

1) Dismantle and clean all the dust, chips and foreign matter from moving parts.

2) Electrical system:

Carefully examine the connection of all electrical wires, terminals and switches,

which occasionally have been damaged by chips or other.

4. Semi-yearly Inspection:

1) Change oil in gearbox:

Remove the used oil from gearbox of headstock, feed and replenish with fresh oil.

2) Check the wear and tear of all gears and packing:

Inspect the damage of all gears in various box, spindle and bearings, and packing. Repair or replace it if necessary.

3) Check the clearance fit of complicated feed mechanism:

Check the clearance fit between feeding screw lever and nut and main screw spindle and nut whether they are right or not.

4) The stability of machine body:

Tighten up the foundation bolts of machine body to the ground and make the body stable.

5. Yearly Inspection:

1) Positioning and leveling:

According to the inspection regulation, recheck the positioning and leveling after a year service.

2) Inspection for accuracy:

According to the regulation. Inspection work for accuracy should be rechecked. If the accuracy is over specified limit, the adjustment or alignment will be done accordingly.

3) Bearing inspection:

Reexamine the insulating materials and clearance fit & lubrication of all bearings.

4) Inspection for appearance:

- a. If paints are peeled off, repaint it with the same color.
- b. Check the exposed parts whether they have been damaged, corroded, or deformed, repair or replace them if necessary.

10. Trouble shooting portion of machine

TROUBLE	PROBABLE CAUSES	REMEDY
Overheat of headstock bearing	1. Oil level in headstock is too low or too high. 2. Quality and viscosity of oil is wrong 3. Oil is too dirty. 4. Oil hole in bearing obstructed by dirt. 5. Bearing obstructed by dirt. 6. Badly worn bearing. 7. bearing in its case is not improper position. 8. Bent or sprung main spindle. 9. Too much end thrust.	Check the oil level and replenish or discharge the oil to the proper level. Replace the oil with recommended one. Replace oil. Remove the dirt from the oil hole. Clean the bearing and renew oil. Replace bearing. Dismantle and reassemble it. Replace main spindle. Adjust thrust nut.
Oil leakage from gearbox.	10. Plug of drain not tightly. 11. Headstock cracking, 12. Leakage from overflow headstock cover. 13. Leakage from overflow spindle bearing house.	Remove recement threat; replace and tighten. Repaired by special welding. Tighten cover screw or replace gasket. Replace oil ring.
Excess noise of vibration of machine	14. Badly worn bearing. 15. Badly worn gear. 16. Bent or sprung shaft. 17. lose of foundation bolts.	Replace bearing. Replace gear. Replace shaft. Tight foundation bolts.

TROUBLE	PROBABLE CAUSES	REMEDY
Chatter	18. Clamp of work piece in from loose status. 19. Spindle bearing thrust too loose. 20. Headstock is not tight with bedway. 21. Excess clearance between carriage and bedway. 22. Excess clearance in cross or compound slide. 23. Cutting angle of cutting tool is not correct. 24. Edge of cutting tool has been worn-out. 25. Weak of tool shank and too long for extension. 26. Tool fixed to holder not tight enough. 27. Unbalances of workpiece or chuck when high speed revolution. 28. Front point of cutting tool not in correct position.	Tighten clamp. Adjust bearing thrust. Tighten headstock screw. Adjust carriage back clamp. Adjust taper gib. Regrind tools to correct cutting angles. Regrind cutting tool. Replace with rigid tools or reset the tools. Tighten tool again. Balance or reduce spindle speed revolution. Reset cutting tool.
Bending, when long workpiece cutting	29. Feed valve too large. 30. Workpiece too thin or too long.	Reduce feed valve size. Use following rest and adjust position of tool.
Accuracy of product fails	31. Accuracy fails in machining.	Check the accuracy of correlation between products and machine (ref. Accuracy chart.)
Uneasy to hold gear change lever.	32. Set spring broken or too weak.	Adjust adjusting screw or replace the spring.

TROUBLE	PROBABLE CAUSES	REMEDY
Misalignment of chuck with main spindle	33. Incorrect position of cam.	Adjust cam and lock in proper position.
Uneasy to cut thread	34. Excessive clearance of lead screw in axial direction. 35. Excessive clearance between saddle and cross slide or cross slide and tool post slide. 36. Worm thread or nut in cross slide or tool post slide. 37. Excessive clearance of hand-wheel.	Adjust the thrust nut of the lead screw holder. Adjust slide gib to proper position. Adjust or replace it. Adjust the set bushing of hand-wheel.
Tailstock is uneasy to clamp with bed stably	38. Clamp handle lever too long or too short.	Adjust the adjusting nut of clamp block.

11.Parts List Assembly

Headstock

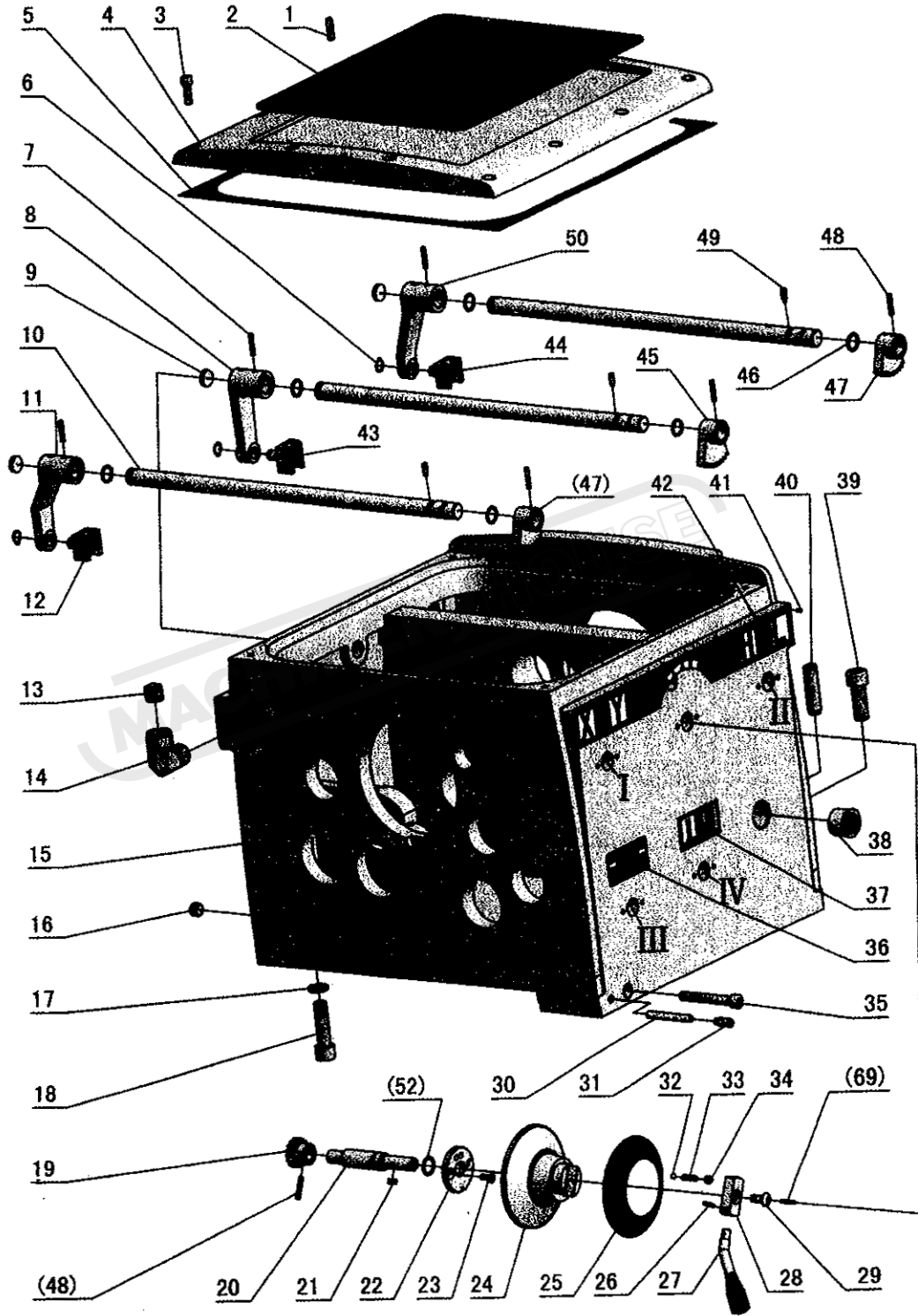

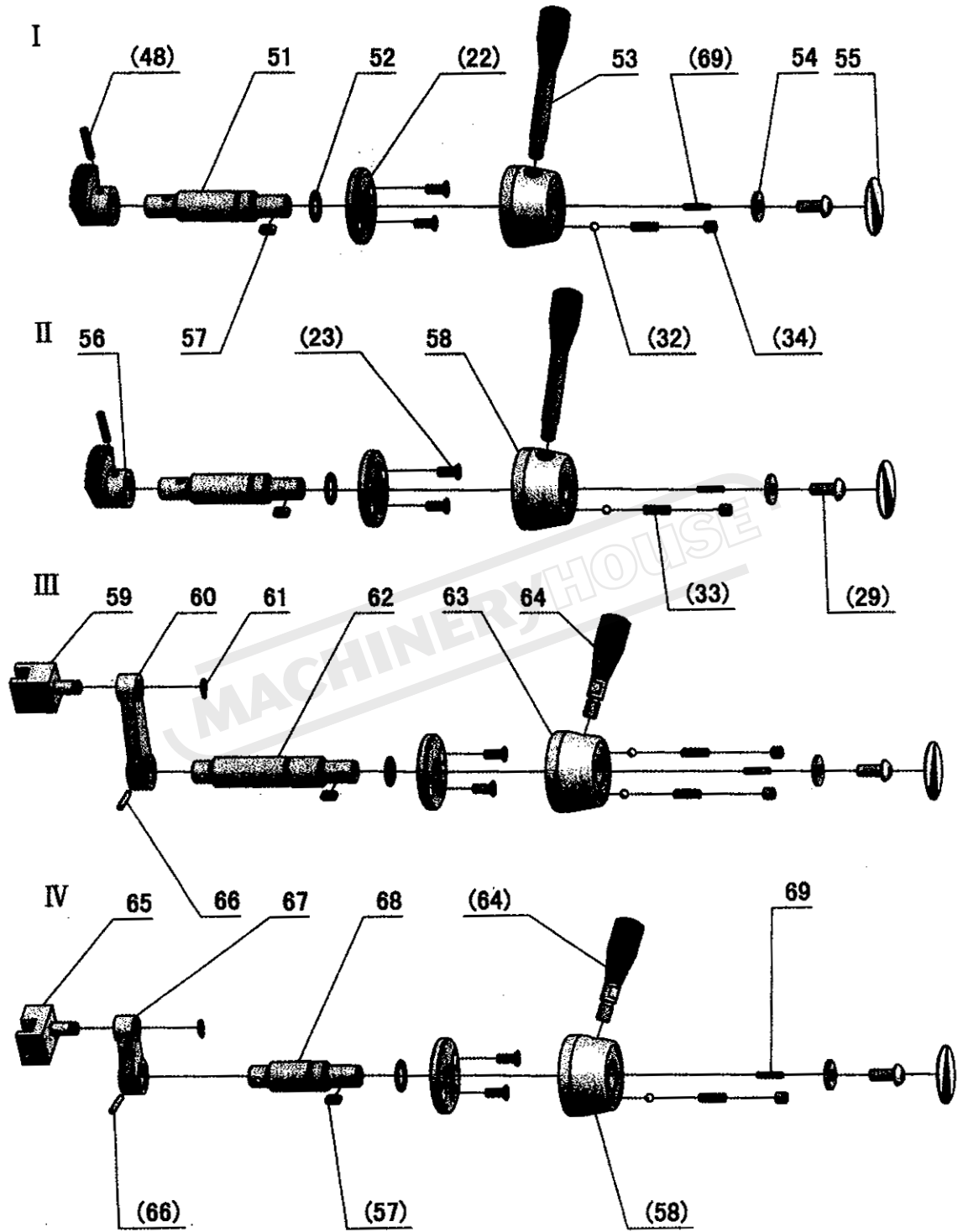

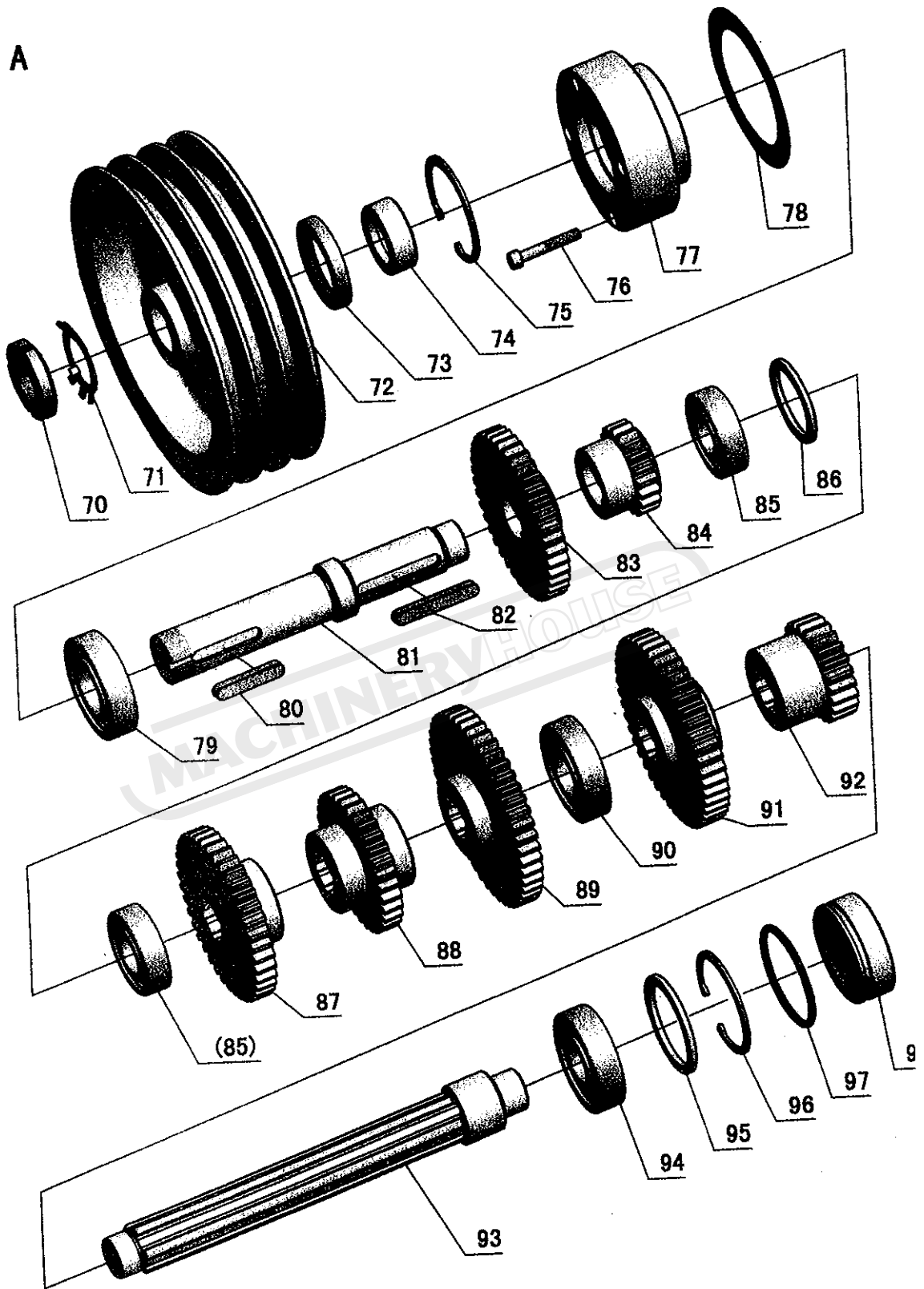

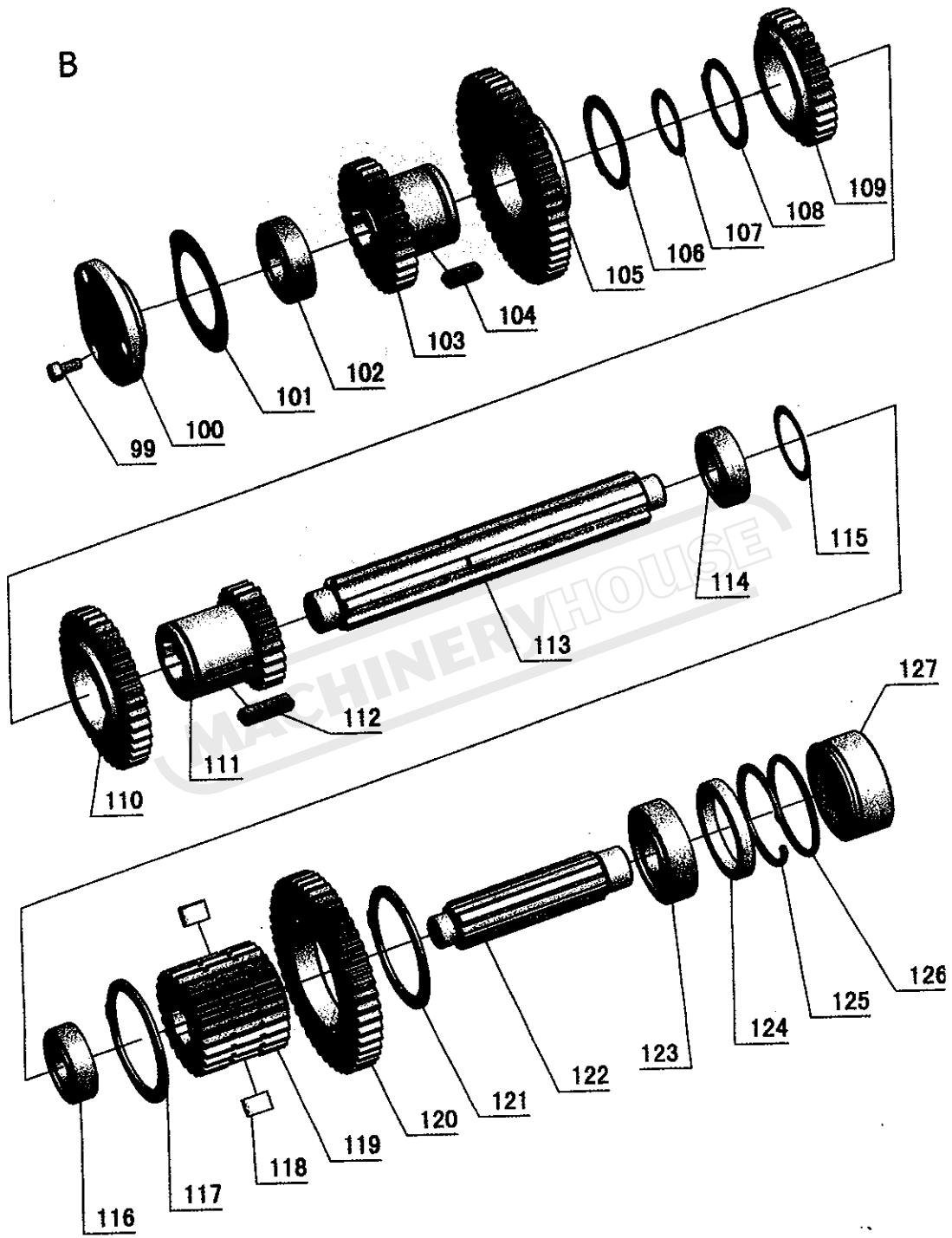

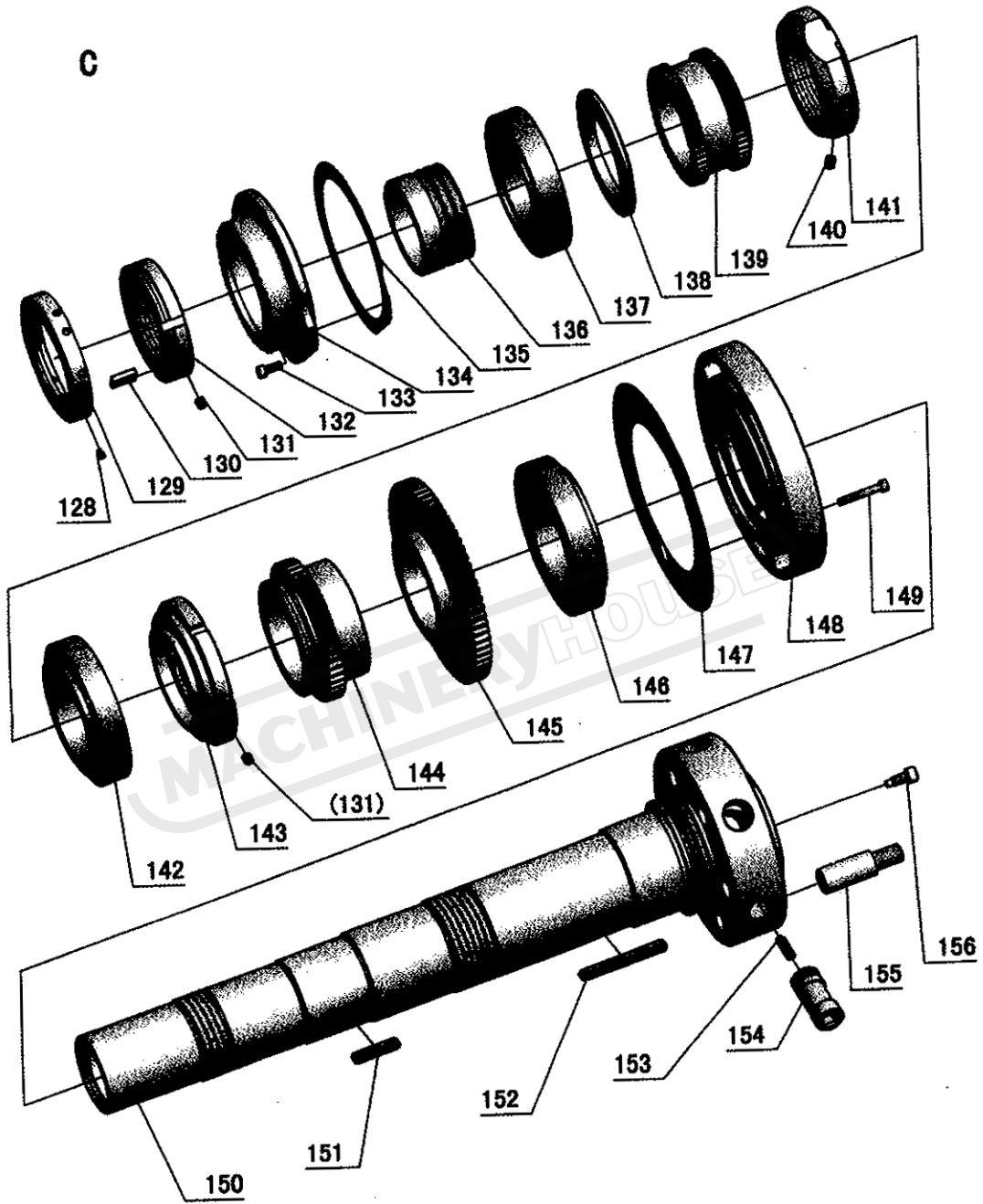

D

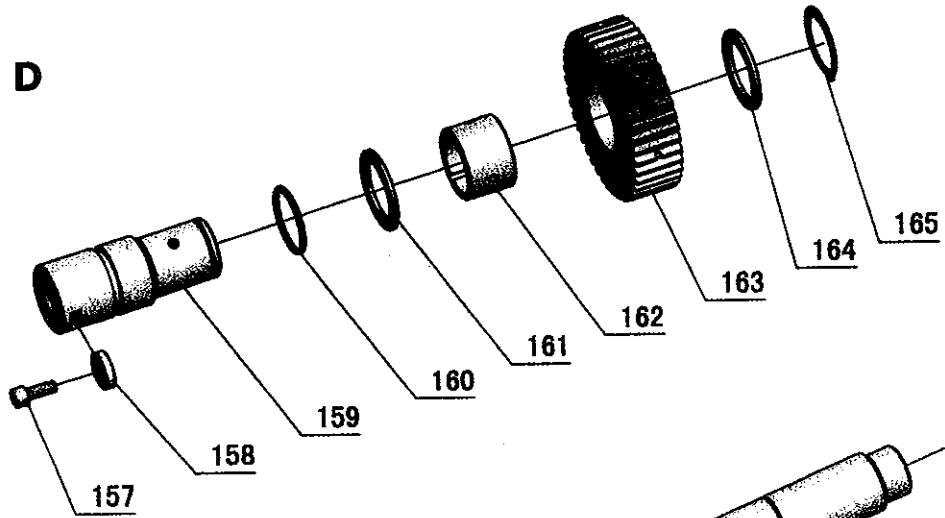

E

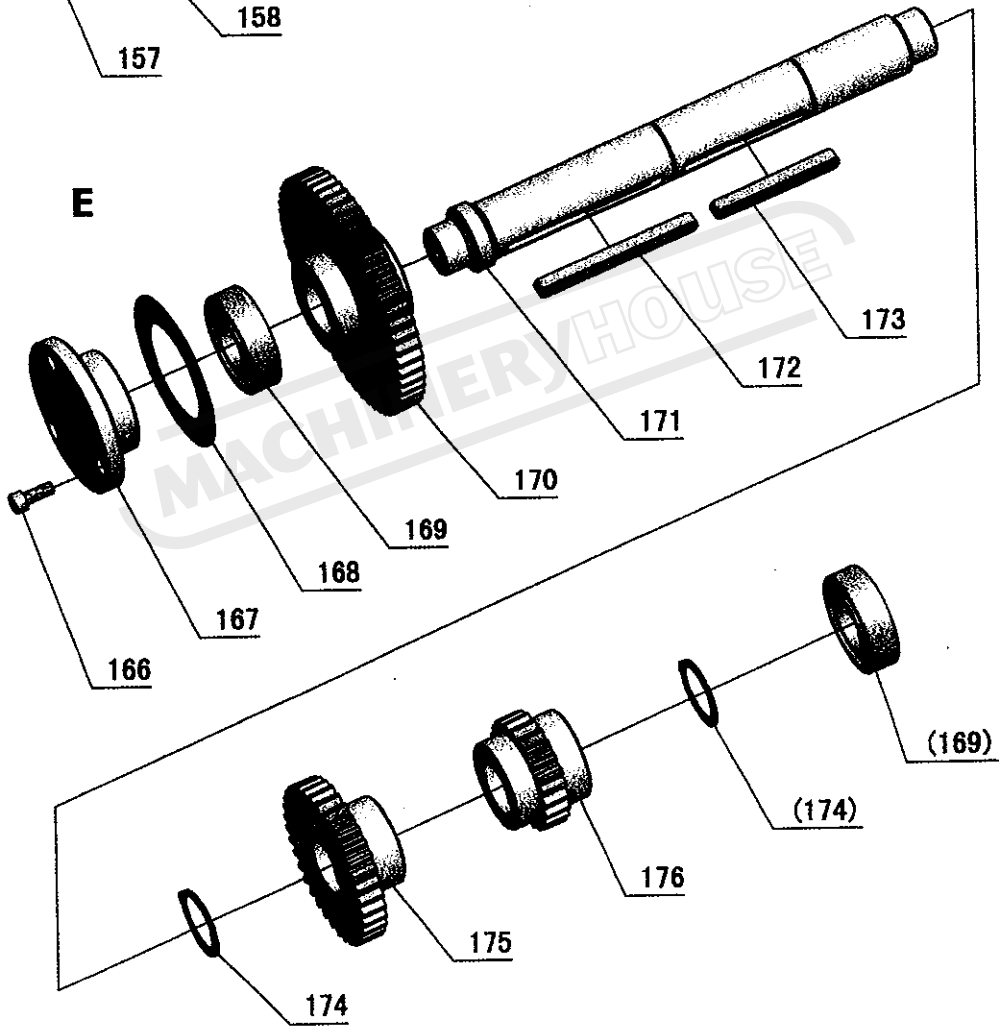

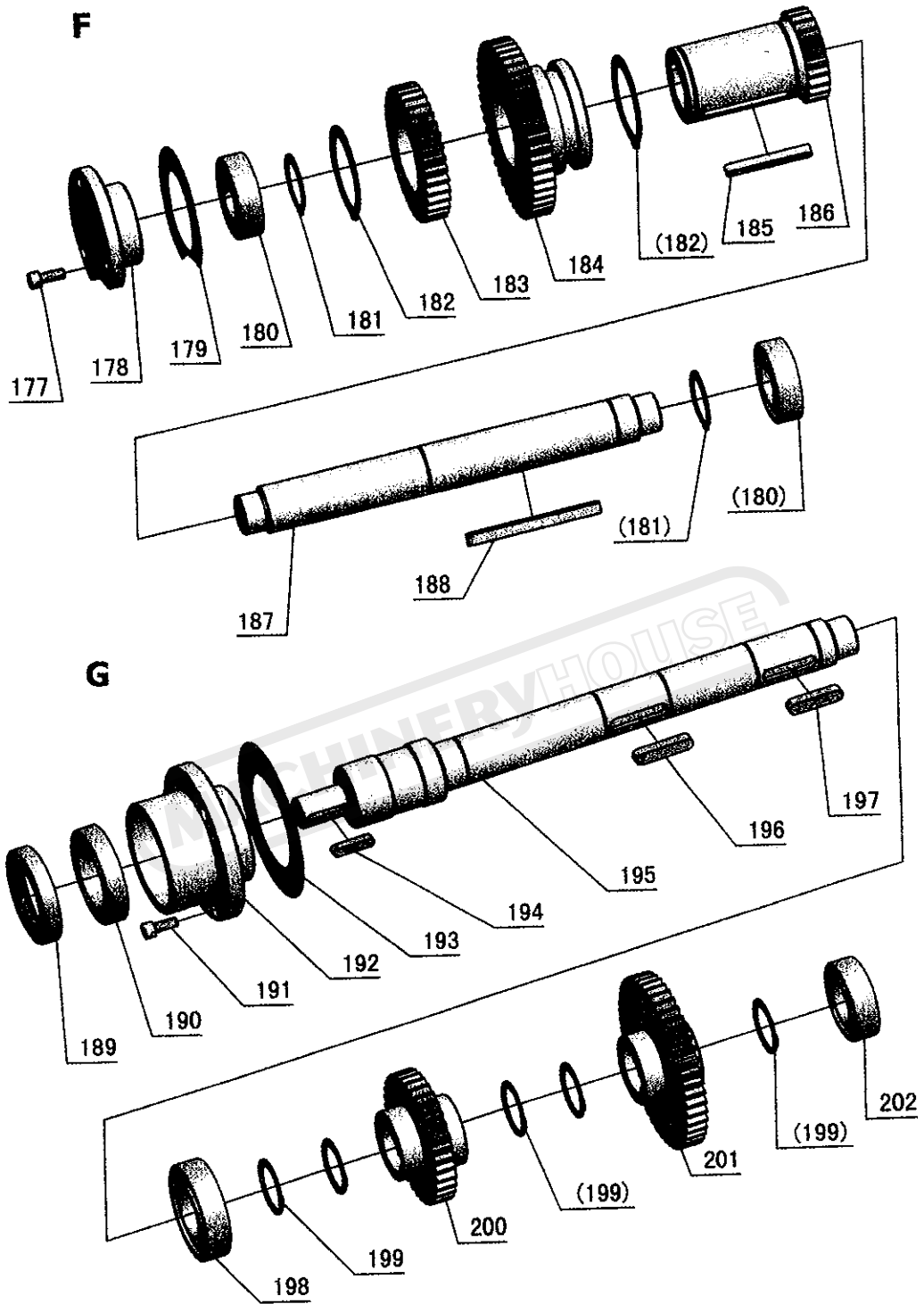

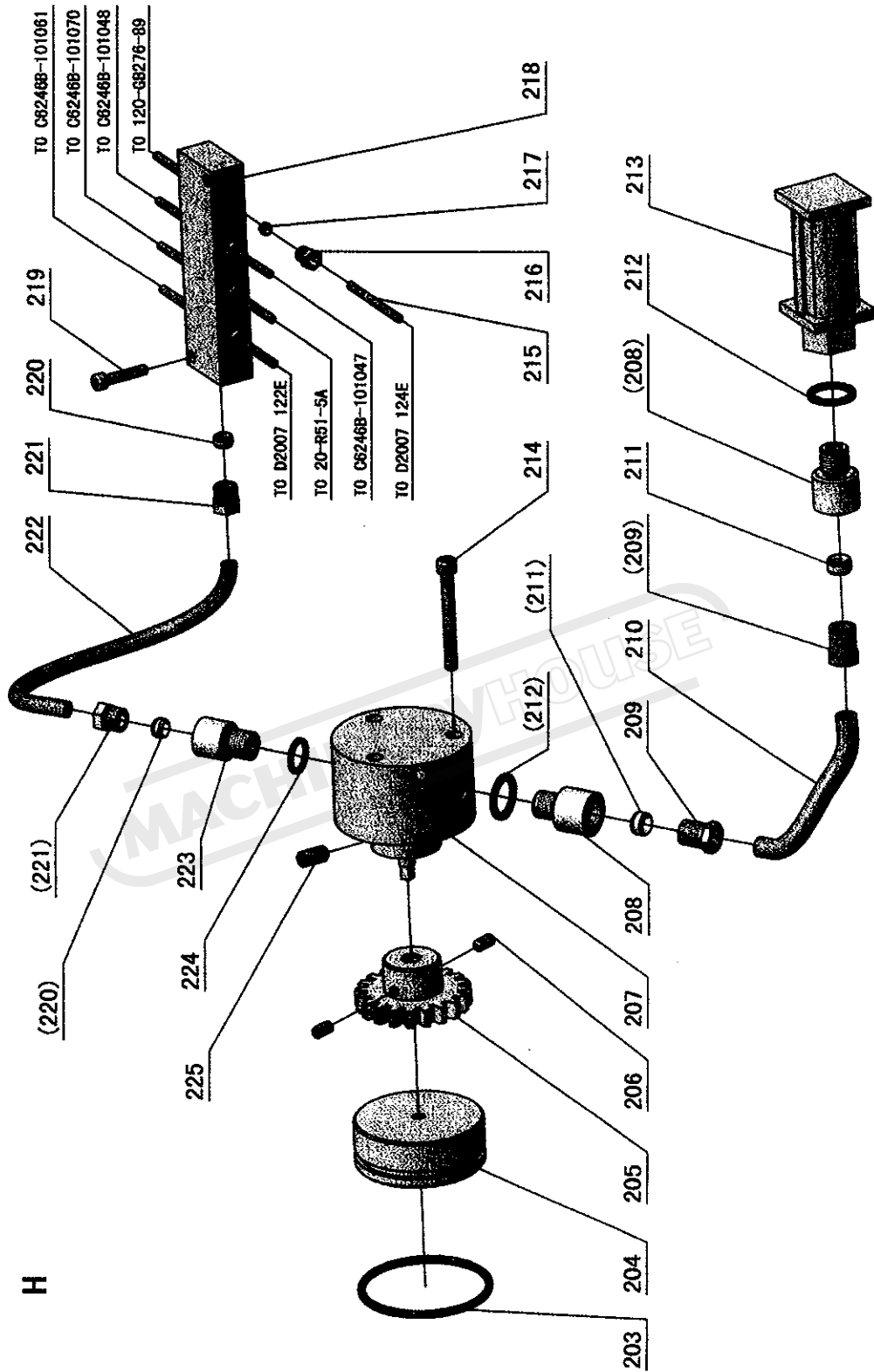

No.	Part No.	Name	Specification	Qty.
1	GB77-85	Screw	M8 × 25	1
2	C6246B-101003	Cover Dress		1
3	GB70-85	Screw	M8 × 20	4
4	C6246B-101002	Headstock Cover		1
5	C6246B-101002-1	Sealed Mat		1
6	GB894.1-86	Circlip	12	3
7	GB879-86	Spring Pin	5 × 30	3
8	C6246B-101011	Lever		1
9	RUN6246-101083	Plug		3
10	RUN6246-101059	Shaft		3
11	C6246B-101022	Lever		1
12	C6246B-101021	Fork		1
13	SB4032-65	Plug		1
14	SB4010-65	Tube Fitting		1
15	C6251A-04-01	Headstock		1
15	C6256A-04-01	Headstock		1
16	G38-3A	Oil Plug	Z 3/8"	1
17	GB93-87	Washer	16	3
18	GB70-85	Socket Head Cap Screw	M16 × 55	3
19	C6246B-101004-1	Gear		1
20	RUN6246-101065-1	Shaft		1
21	GB1096-79	Flat Key	5 × 12	1
22	RUN6246-101067	Fix Plate		5
23	GB819-85	Screw	M6 × 16	10
24	RUN6246-101077-1	Handle		1
25	RUN6246-101097	Plate		1
26	GB879-86	Spring Pin	4 × 20	1
27	RUN6246-101077-3	Lever		1
28	RUN6246-101077-2	Fix Bracket		1
29	RUN6246-101088	Round Head Screw		5
30	RUN6246-101080	Pin		2
31	GB79-85	Socket Head Set Screw	M10 × 25	2
32	GB308-84	Steel Ball	1/4"	6
33	RUN6246-101066	Spring		6
34	GB77-85	Screw	M8 × 8	6
35	GB70-85	Screw	M10 × 110	1
36	C6246B-101098	Plate		1
37	C6246B-101100	Plate		1
38	R51-5A	Oil Sight Glass	20	1
39	GB70-85	Screw	M16 × 55	3

No.	Part No.	Name	Specification	Qty.
40	GB120-86	Pin	16 × 55	1
41	GB827-86	Rivet	2 × 5	24
42	C6246B-101006	Plate		1
43	C6246B-101012	Fork		1
44	C6246B-101012-1	Fork		1
45	C6246B-101005-1	Gear		1
46	GB1235-76	O-Ring	20 × 2.4	6
47	C6246B-101005	Gear		2
48	GB879-86	Spring Pin	5 × 26	6
49	GB79-85	Screw	M6 × 6	3
50	C6246B-101018	Lever		1
51	RUN6246-101065	Shaft		2
52	GB1235-76	O-Ring	22 × 2.4	5
53	RUN6246-101072	Lever		2
54	RUN6246-101070-1	Washer		4
55	RUN6246-101099	Plate		4
56	RUN6246-101064	Gear		2
57	GB1096-79	Key	5 × 12	4
58	RUN6246-101071	Lever Head		3
59	C6246B-101008	Fork		1
60	C6246B-101009	Lever		1
61	GB894.1-86	Circlip	10	2
62	C6246B-101017-1	Shaft		1
63	RUN6246-101077A	Handle		1
64	C6246B-101010	Lever		2
65	C6246B-101015	Fork		1
66	GB879-86	Spring Pin	4 × 26	2
67	C6246B-101016	Lever		1
68	C6246B-101017	Shaft		1
69	GB77-85	Screw	M4 × 20	5
70	GB812-88	Nut	M30 × 1.5	1
71	GB858-88	Nut	30	1
72	RUN6246-101011	Pulley		1
73	HG4-692-67	Oil Seal	PD40 × 62 × 12	1
74	GB278-89	Ball Bearing	1080908	1
75	GB893.1-86	Snap Ring	62	1
76	GB70-85	Socket Head Cap Screw	M6 × 30	4
77	C6246B-101024	Bearing Cap		1
78	C6246B-101024-1	Bearing Seat Seal		1
79	GB278-89	Ball Bearing	80306	1

No.	Part No.	Name	Specification	Qty.
80	GB1096-79	Flat Key	8 × 40	1
81	C6246B-101080	Input Shaft		1
82	GB1096-79	Flat Key	8 × 70	1
83	C6246B-101026	Gear		1
84	C6246B-101027	Gear		1
85	GB278-89	Ball Bearing	80205	2
86	C6246B-101028	Spacer		3
87	C6246B-101029	Gear		1
88	C6246B-101030	Gear		1
89	C6246B-101031	Gear		1
90	GB278-89	Ball Bearing	80206	1
91	C6246B-101032	Gear		1
92	C6246B-101033	Gear		1
93	C6246B-101035	Spline Shaft		1
94	GB278-89	Ball Bearing	80305	1
95	C6246B-101034-2	Washer		1
96	GB893.1-86	Snap Ring	62	1
97	GB3452.1-82	O-Ring	56 × 2.65	1
98	RUN6246-101019-1	Plug		1
99	GB70-85	Socket Head Cap Screw	M6 × 16	3
100	C6246B-101079	Bearing Cover		1
101	C6246B-101079-1	Bearing Cover Seal		1
102	GB278-89	Ball Bearing	80205	1
103	C6246B-101077	Gear		1
104	GB1096-79	Flat Key	8 × 20	1
105	C6246B-101076	Gear		1
106	GB894.1-86	Snap Ring	52	1
107	GB894.1-86	Snap Ring	34	2
108	GB894.1-86	Snap Ring	48	1
109	C6246B-101039	Gear		1
110	C6246B-101040	Gear		1
111	C6246B-101041	Gear		1
112	GB1096-79	Flat Key	8 × 32	1
113	C6246B-101078	Spline Shaft		1
114	GB278-89	Ball Bearing	80205	1
115	C6246B-101028	Spacer		3
116	GB278-89	Ball Bearing	80205	1
117	GB894.1-86	Snap Ring	75	1
118	C6246B-101036-1	Flat Key		2
119	C6246B-101038	Gear		1

No.	Part No.	Name	Specification	Qty.
120	C6246B-101036	Gear		1
121	GB894.1-86	Snap Ring	75	1
122	C6246B-101037	Spline Shaft		1
123	GB278-89	Ball Bearing	80305	1
124	C6246B-101034-2	Washer		1
125	GB893.1-86	Snap Ring	62	1
126	GB3452.1-82	O-Ring	56 × 2.65	1
127	RUN6246-101019-1	Protection Cover		1
128	GB79-85	Socket Head Set Screw	M6 × 8	4
129	C6246B-101073	Balance Block		2
130	C6246B-101074-1	Brass		1
131	GB79-85	Socket Head Set Screw	M10 × 10	1
132	C6246B-101074	Lock Nut		1
133	GB70-85	Socket Head Cap Screw	M6 × 20	4
134	C6246B-101075	Rear Bearing Cover		1
135	C6246B-101075-1	Rear Spindle Bearing Cover Sealer		1
136	C6246B-101072	Oil Ring		1
137	GB276-89	Ball Bearing	120	1
138	C6246B-101071	Shaft Ring		1
139	C6246B-101070	Gear		1
140	GB79-85	Socket Head Set Screw	M8 × 10	3
141	C6246B-101045	Lock Nut		1
142	GB297-84	Ball Bearing	D2007122E	1
143	C6246B-101046	Lock Nut		1
144	C6246B-101047	Gear		1
145	C6246B-101048	Gear		1
146	GB297-84	Ball Bearing	D2007124E	1
147	C6246B-101051-1	Front Bearing Cover Seal		1
148	C6246B-101051	Front Bearing Cover	D1-8	1
149	GB70-85	Socket Head Cap Screw	M6 × 40	5
150	C6246B-101049-1	Spindle		1
151	GB1096-79	Flat Key	10 × 80	1
152	GB1096-79	Flat Key	10 × 90	1
153	RUN6246-101082-1	Spring		6
154	C6246B-101042	Cam Lock For D1-8		6
155	C6246B-101050	Cam Screw For D1-8		6
156	C6246B-101044	Screw For D1-8		6
157	GB70-85	Socket Head Cap Screw	M6 × 16	1
158	RUN6246-101048	Spacer		1
159	C6246B-101061	Stationary Pulley Shaft		1

No.	Part No.	Name	Specification	Qty.
160	GB1235-76	O-Ring	30 × 2.4	1
161	C6246B-101059	Spacer		1
162	C6246B-101060-1	Brass		1
163	C6246B-101060	Stationary Pulley		1
164	C6246B-101059	Spacer		1
165	GB894.1-86	Snap Ring	30	1
166	GB70-85	Socket Head Cap Screw	M6 × 16	3
167	C6246B-101068	Bearing Cover		1
168	C6246B-101068-1	Bearing Cover Seal		1
169	GB278-89	Ball Bearing	80205	1
170	C6246B-101066	Gear		1
171	C6246B-101069	Shaft		1
172	GB1096-79	Flat Key	8 × 90	1
173	GB1096-79	Flat Key	8 × 70	1
174	GB894.1-86	Snap Ring	30	2
175	C6246B-101053	Gear		1
176	C6246B-101052	Gear		1
177	GB70-85	Socket Head Cap Screw	M6 × 16	13
178	C6246B-101067	Bearing Cover		1
179	C6246B-101067-1	Bearing Cover Seal		1
180	GB278-89	Ball Bearing	80205	1
181	GB894.1-86	Snap Ring	30	2
182	GB894.1-86	Snap Ring	48	2
183	C6246B-101057	Gear		1
184	C6246B-101056	Gear		1
185	GB1096-79	Flat Key	6 × 56	1
186	C6246B-101055	Gear		1
187	C6246B-101065	Shaft		1
188	GB1096-79	Flat Key	8 × 90	1
189	HG4-692-67	Oil Seal	PD40 × 62 × 12	1
190	GB278-89	Ball Bearing	1080908	1
191	GB70-85	Socket Head Cap Screw	M6 × 20	3
192	C6246B-101063	Bearing Seat		1
193	C6246B-101063-1	Bearing Seat Seal		1
194	GB1096-79	Flat Key	6 × 28	1
195	C6246B-101064	Output Shaft		1
196	GB1096-79	Flat Key	8 × 40	1
197	GB1096-79	Flat Key	8 × 36	1
198	GB278-89	Ball Bearing	80206	1
199	GB894.1-86	Snap Ring	30	5

No.	Part No.	Name	Specification	Qty.
200	C6246B-101058	Gear		1
201	C6246B-101054	Gear		1
202	GB278-89	Ball Bearing	80205	1
203	GB1235-76	O-Ring	68 × 3.1	1
204	C6246B-101082	Protection		1
205	C6246B-101081	Gear		1
206	GB80-85	Screw	M6 × 12	2
207	SNBY2.5/0.5	Oil Pump	M14 × 1.5	1
208	C6246B-101088	Conjunctional Block		1
209	25568	Tie-In		2
210	GB1527-79-M-T3	Brass Tube	10 × 0.75	1
211	25677	Double Taper Sheath		2
212	GB52-2	Washer	18	1
213	Wu-16 × 180-J	Filter		1
214	GB70-85	Screw	M6 × 55	3
215	GB1527-79-M-T3	Brass Tube	4 × 0.75	1
216	15326C	Tie-In		9
217	B1061C	Double Taper Sheath		9
218	C6246B-101084	Manifold		1
219	GB70-85	Socket Head Cap Screw	M5 × 25	2
220	B145C	Double Taper Sheath		2
221	25567	Tie-In		2
222	GB1527-79-M-T3	Brass Tube	8 × 0.75	1
223	C6246B-101086	Conjunctional Block		1
224	G52-2	Washer	14	2
225	GB80-85	Screw	M6 × 16	1

Gearbox

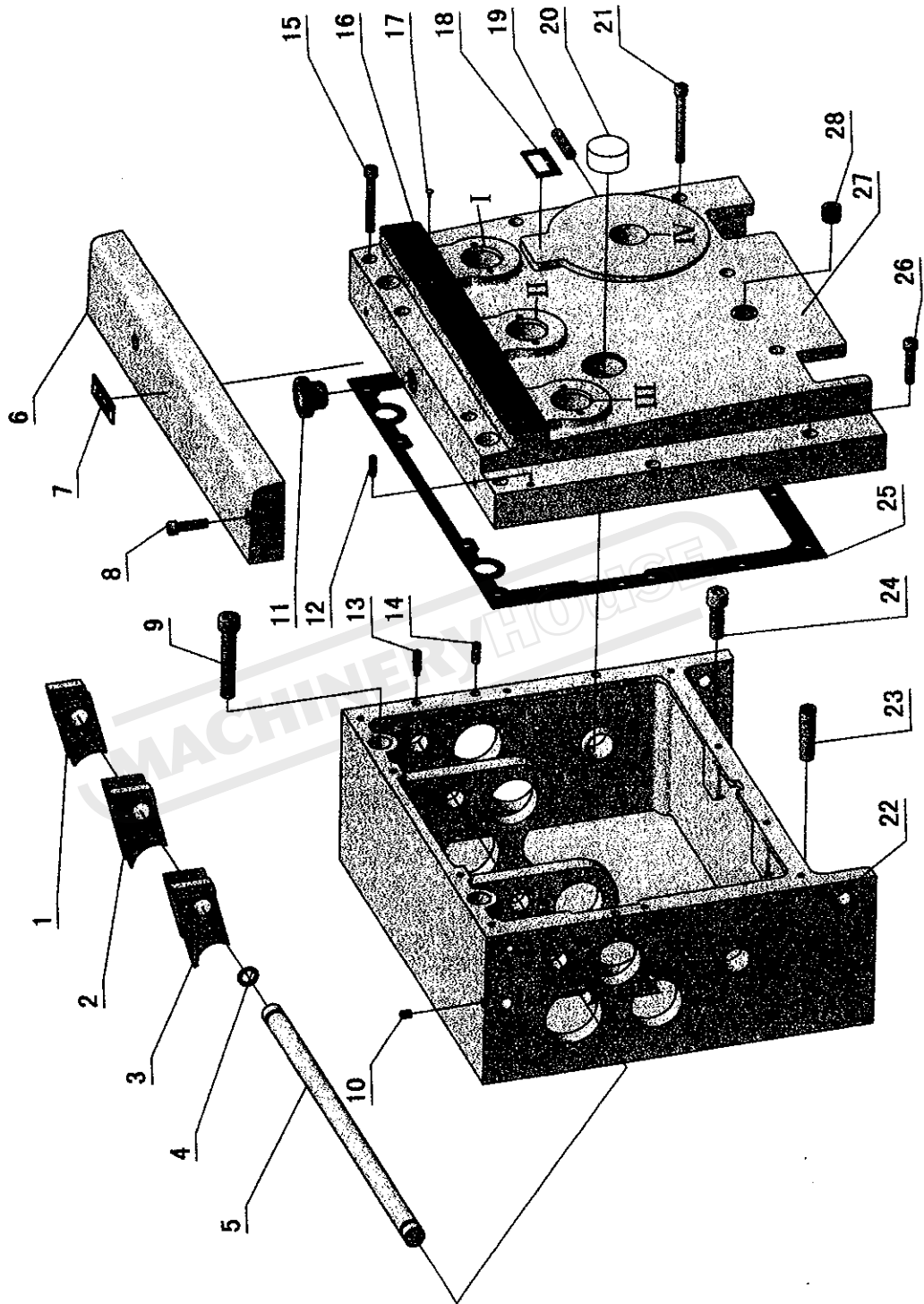

A

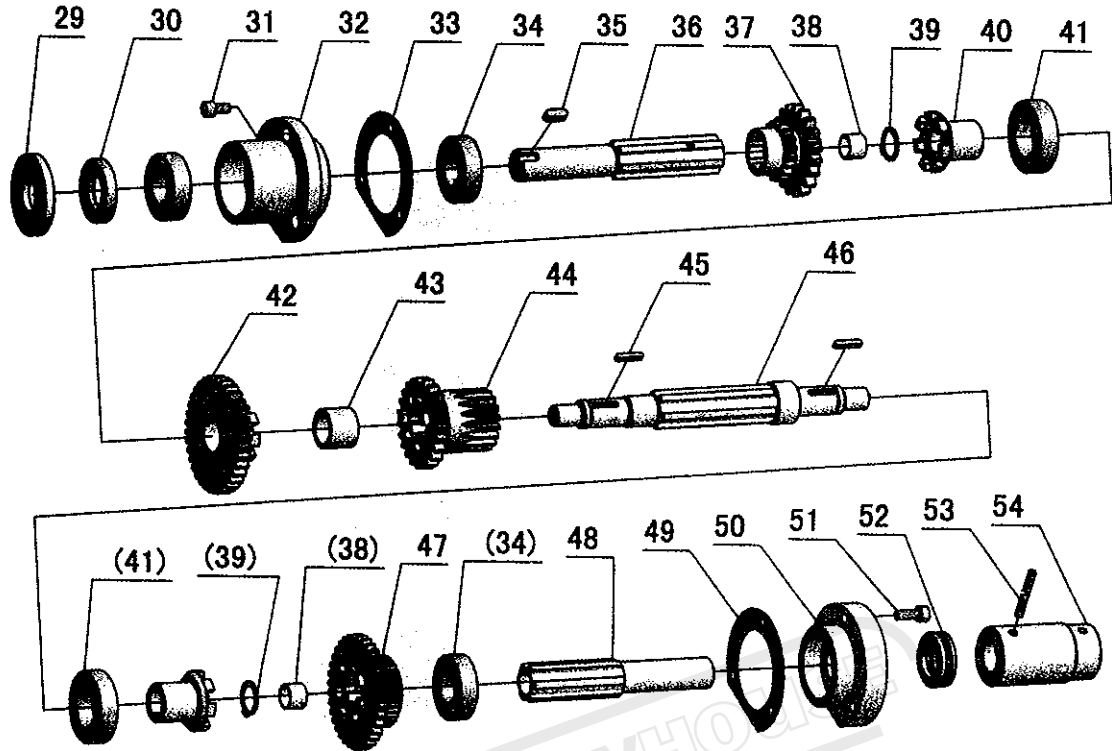

B

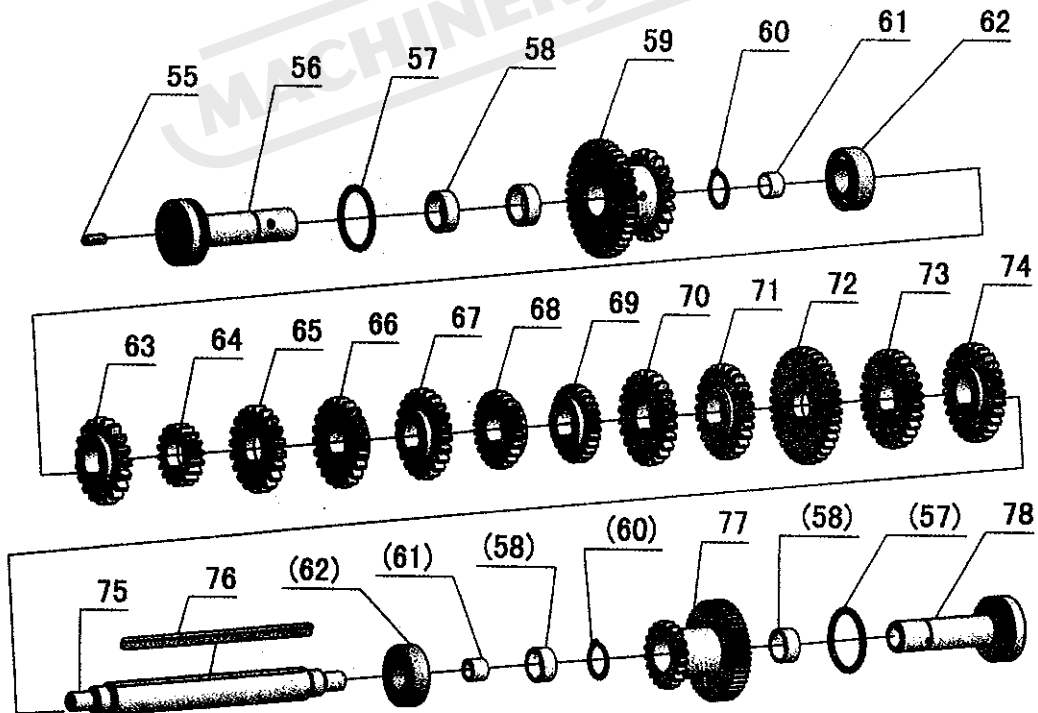

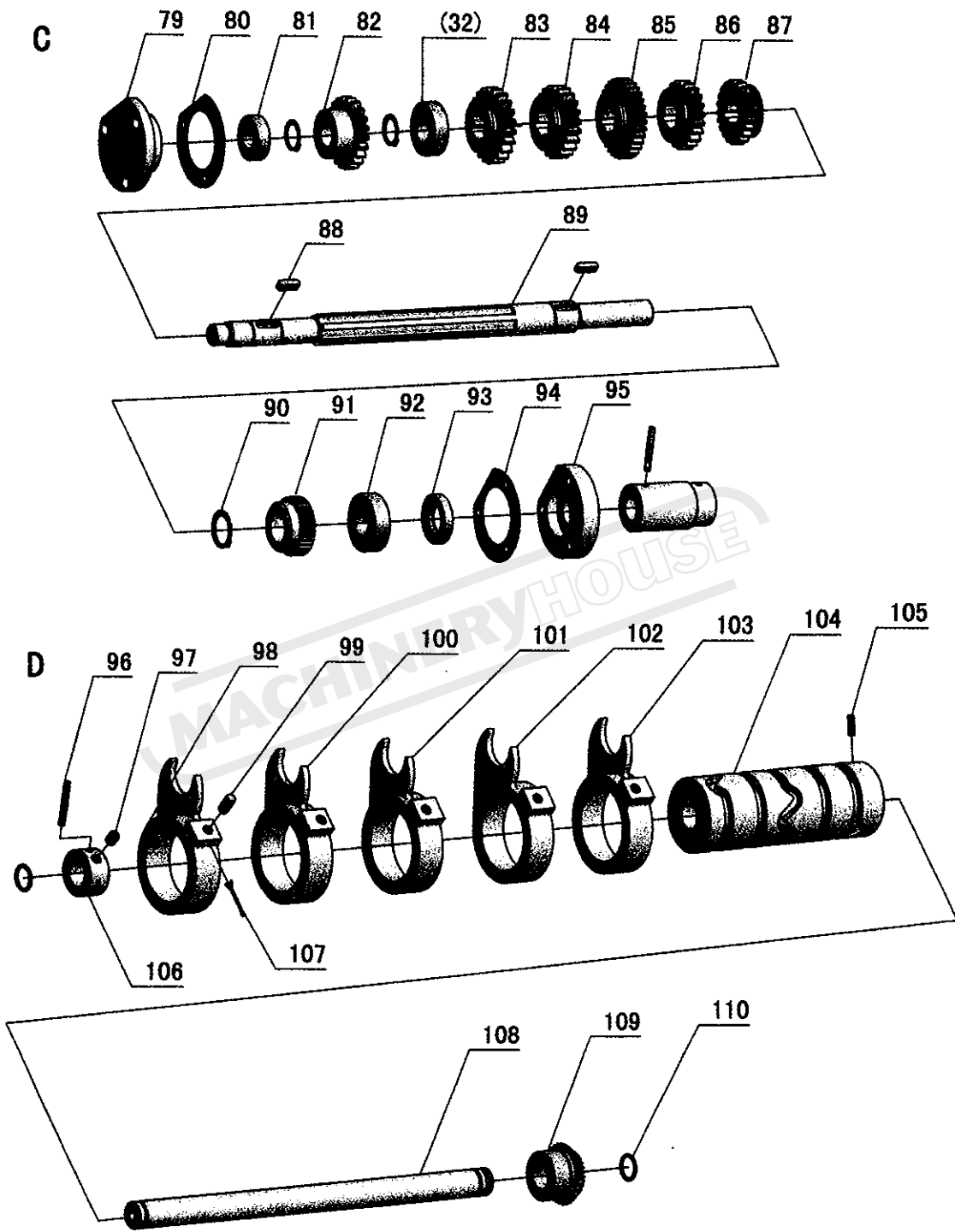

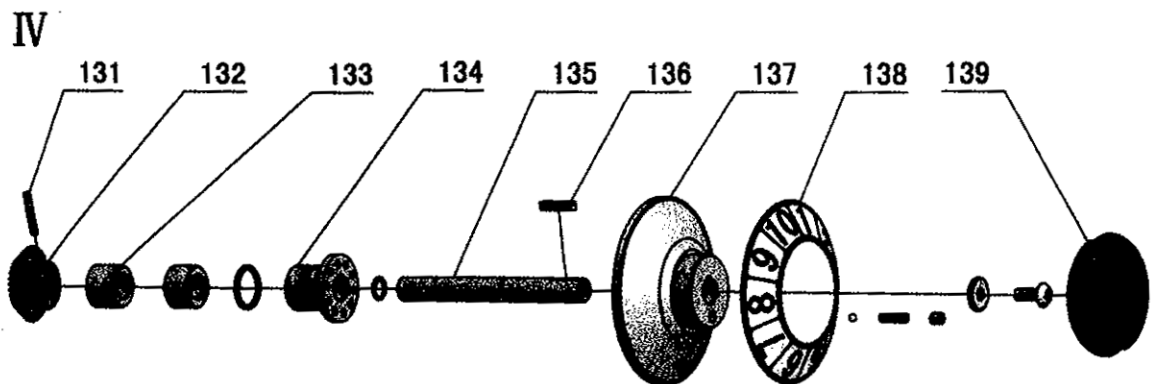
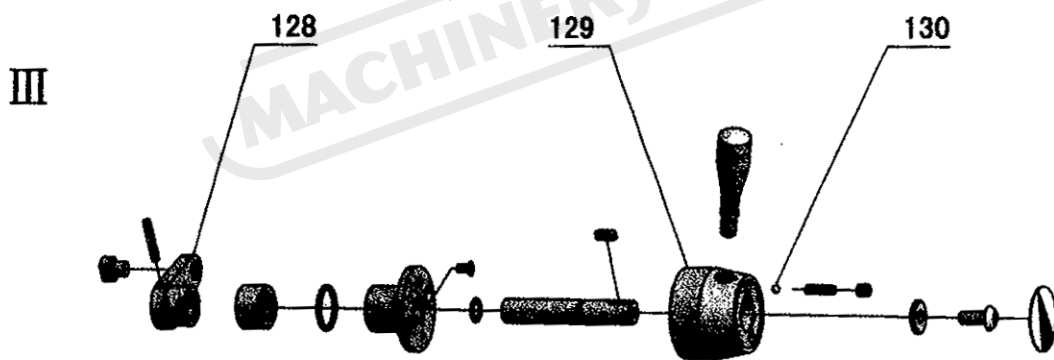
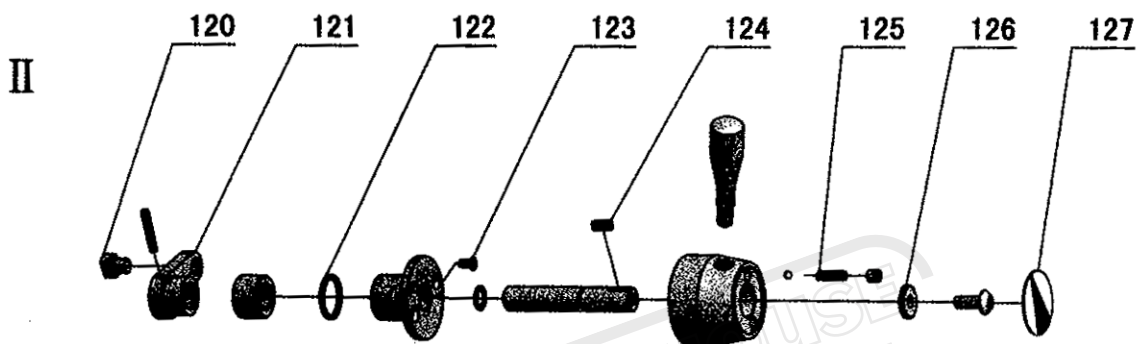
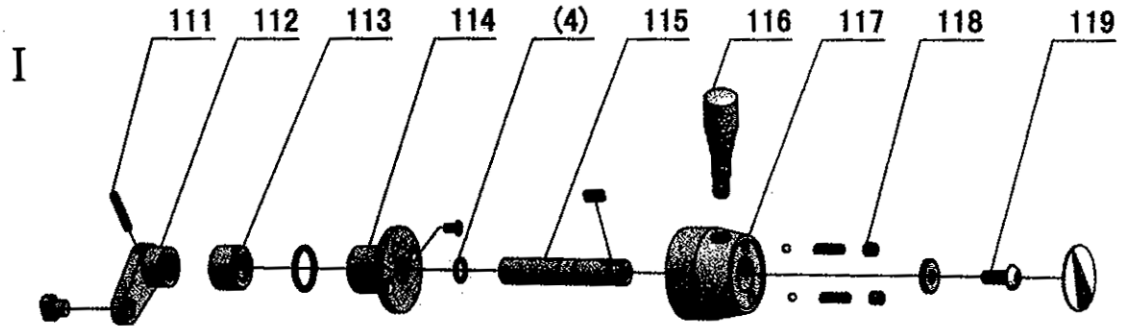

No.	Part No.	Name	Specification	Qty.
1	RUN6141-102070-1	Fork		1
2	RUN6246-102069	Fork		1
3	RUN6246-102069-1	Fork		1
4	GB1235-76	O-Ring	16 × 2.4	6
5	RUN6246-102077	Shaft		1
6	C6251A-05-06	Top Cover		1
7	RUN6246-102079	Plate		1
8	GB70-85	Screw	M6 × 30	2
9	GB70-85	Screw	M10 × 60	2
10	GB78-85	Screw	M6 × 8	1
11	RUN6246-103031	Oil Cover		1
12	GB879-86	Spring Pin	5 × 16	2
13	GB79-85	Socket Set Screw	M6 × 20	2
14	GB78-85	Screw	M6 × 16	2
15	GB70-85	Screw	M6 × 50	1
16	RUN6246-102080	Plate		1
17	GB827-86	Rivet	2 × 5	10
18	RUN6246-102081	Plate		1
19	GB78-85	Screw	M8 × 35	1
20	GB1160.1-89	Oil Sight Glass	20	1
21	GB70-85	Screw	M6 × 60	3
22	RUN6246-102001A	Gear Box		1
23	GB118-86	Taper Pin	10 × 45	2
24	GB70-85	Screw	M10 × 30	2
25	RUN6246-102001-2A	Sealed Mat		1
26	GB70-85	Screw	M6 × 30	3
27	RUN6141-102002A	Front Cover		1
28	G38-3A	Oil Plug	Z 3/8"	1
29	C6251A-05-05	Spacer		1
30		Oil-Seal	TC20 × 42 × 8	1
31	GB70-85	Socket Head Cap Screw	M6 × 12	6
32	RUN6246-102050	Cap		1
33	RUN6246-102050-1	Sealed Mat		1
34	GB278-89	Ball Bearing	80104	4
35	GB1096-79	Key	6 × 10	1
36	C6251A-05-04	B-Shaft		1
37	RUN6246-102048	Gear		1
38	SF-1	Ball Bearing	1410	2
39	GB894.1-86	Snap Ring	18	2
40	RUN6246-102047	Clutch		2

No.	Part No.	Name	Specification	Qty.
41	GB278-89	Ball Bearing	80105	2
42	RUN6246-102046	Gear		1
43	SF-1	Ball Bearing	2020	1
44	RUN6246-102045	Gear		1
45	GB1096-79	Key	4 × 20	2
46	RUN6246-102044	A-Shaft		1
47	RUN6141-102042-1	Gear		1
48	RUN6246-102041	C-Shaft		1
49	RUN6246-102040-1	Sealed Mat		1
50	RUN6246-102040	Cap		1
51	GB70-85	Socket Cap Screw	M6 × 20	6
52	GB301-84	Thrust Bearing	8104	1
53	GB879-86	Spring Pin	5 × 35	2
54	C6251A-05-03	Collar-Linkage		1
54	RUN6246-102012	Collar-Linkage		2
55	GB78-85	Screw	M6 × 16	2
56	RUN6246-102023	E-Shaft		1
57	GB3452.1-82	O-Ring	35.5 × 3.55	2
58	SF-1	Ball Bearing	2012	4
59	RUN6246-102024	Gear		1
60	GB894.1-86	Snap Ring	20	4
61	SF-1	Ball Bearing	1218	2
62	RUN6246-102026	Gear		1
63	RUN6246-102027	Gear		1
64	RUN6246-102028	Gear		1
65	RUN6246-102029	Gear		1
66	RUN6246-102030	Gear		1
67	RUN6246-102031	Gear		1
68	RUN6246-102032	Gear		1
69	RUN6246-102033	Gear		1
70	RUN6246-102034	Gear		1
71	RUN6246-102035	Gear		1
72	RUN6246-102036	Gear		1
73	RUN6246-102037	Gear		1
74	RUN6246-102025	D-Shaft		1
75	GB1096-79	Key	6 × 146	1
76	GB278-89	Ball Bearing	80203	2
77	RUN6141-102038	Gear		1
78	RUN6246-102039	F-Shaft		1
79	RUN6246-102022	Cap		1

No.	Part No.	Name	Specification	Qty.
80	RUN6246-102022-1	Sealed Mat		1
81	GB278-89	Ball Bearing	80103	1
82	RUN6246-102020	Gear		1
83	RUN6246-102019	Gear		1
84	RUN6246-102018	Gear		1
85	RUN6246-102017	Gear		1
86	RUN6246-102016	Gear		1
87	RUN6246-102015	Gear		1
88	GB1096-79	Key	6 × 20	2
89	RUN6246-102021	G-Shaft		1
90	GB894.1-86	Snap Ring	25	1
91	RUN6141-102014-1	Gear		1
92	GB278-89	Ball Bearing	80204	1
93		Oil Seal	TC20 × 40 × 7	1
94	RUN6246-102013-1	Sealed Mat		1
95	RUN6246-102013	Cap-Right		1
96	GB879-86	Spring Pin	5 × 35	1
97	GB78-85	Socket Set Screw	M8 × 10	1
98	RUN6246-102008	Claw-Shifter		1
99	GB119-86	Pin	B8 × 16	5
100	RUN6246-102007	Claw-Shifter		1
101	RUN6246-102006	Claw-Shifter		1
102	RUN6246-102005	Claw-Shifter		1
103	RUN6246-102004	Claw-Shifter		1
104	RUN6246-102009	Cam Shifter		1
105	GB879-86	Spring Pin	5 × 16	2
106	RUN6246-102010	H-Shaft		1
107	GB91-86	Split Pin	2 × 30	5
108	RUN6246-102011	H-Shaft		1
109	RUN6246-102003	Bevel Gear		1
110	GB1235-76	O-Ring	22 × 2.4	2
111	GB879-86	Spring Pin	5 × 30	3
112	RUN6246-102066	Arm		1
113	RUN6141-102062-2	Spacer		4
114	RUN6246-102075	Detent Plate		3
115	RUN6141-102072	Shaft		3
116	RUN6246-102056-1	Lever		3
117	RUN6246-102076	Speed Change Handle		1
118	GB77-85	Screw	M8 × 8	5
119	RUN6246-101088	Screw		4

No.	Part No.	Name	Specification	Qty.
120	RUN6246-102073	Fork		3
121	RUN6246-102067	Arm		1
122	GB1235-76	O-Ring	30 × 3.1	4
123	GB819-85	Screw	M5 × 10	6
124	GB1096-79	Key	5 × 14	3
125	RUN6246-101066	Spring		5
126	RUN6246-101070-1	Washer		4
127	RUN6246-101099	Plate		3
128	RUN6246-102068	Arm		1
129	RUN6246-102065	Speed Change Handle		2
130	GB308-77	Steel Ball	1/4"	5
131	GB879-76	Spring Pin	5 × 30	1
132	RUN6246-102060	Bevel Gear		1
133	RUN6246-102062-1	Spacer		1
134	RUN6246-102062	Shaft Sleeve		1
135	RUN6141-102055	Shaft		1
136	GB1096-79	Key	5 × 28	1
137	RUN6246-102063	Selecting Dial		1
138	RUN6246-102082	Plate		1
139	RUN6246-102053	Wheel		1

Saddle

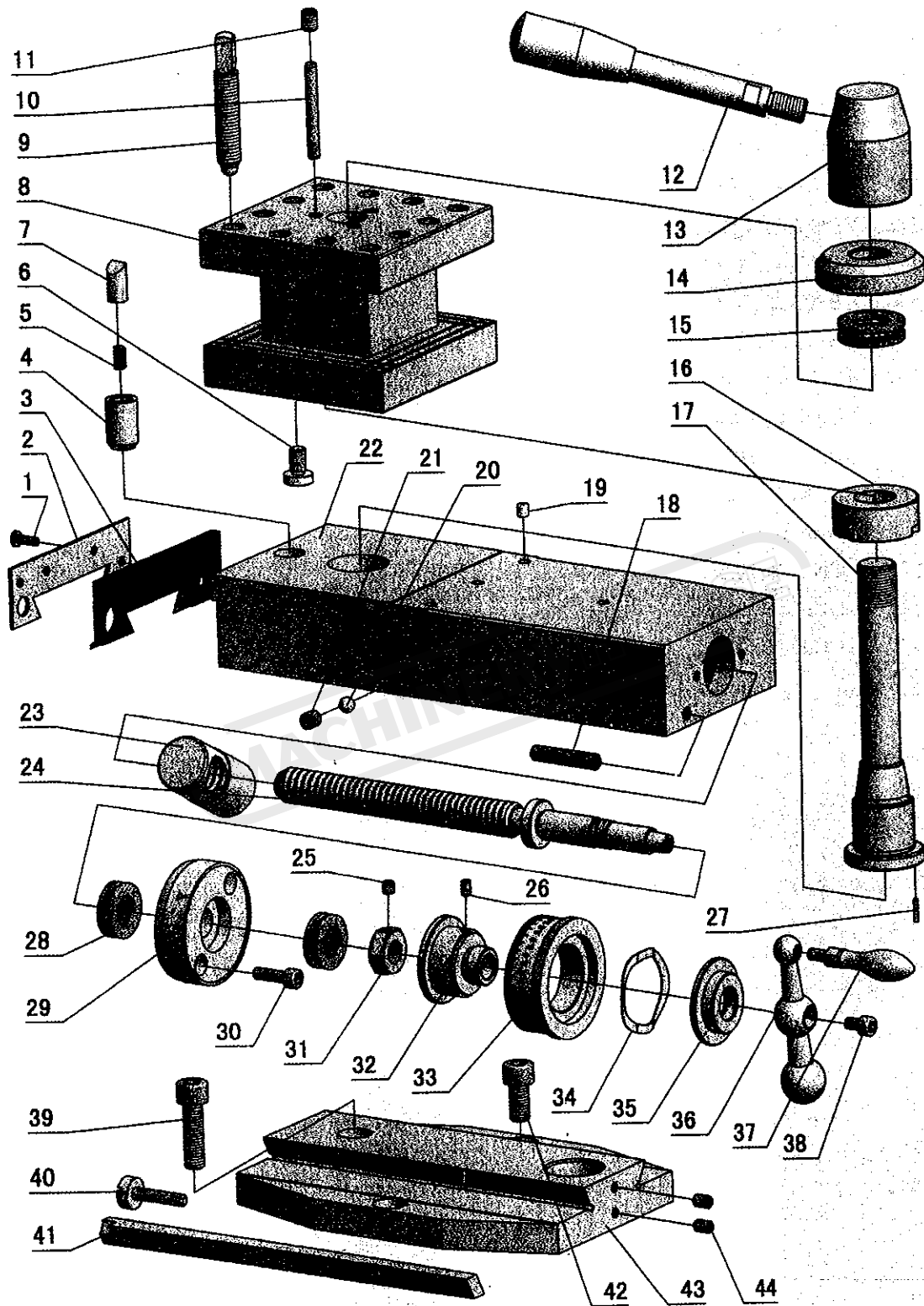

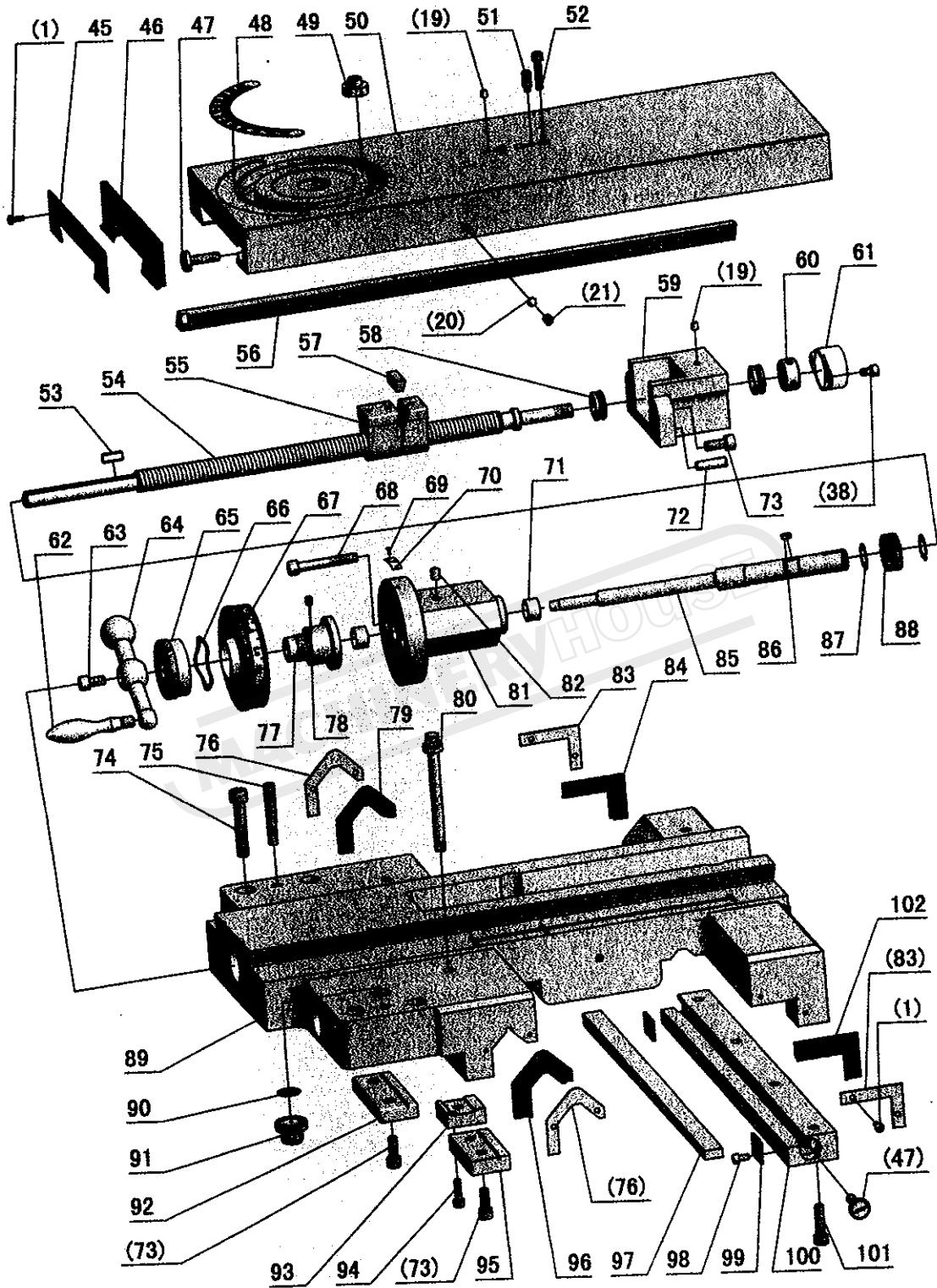

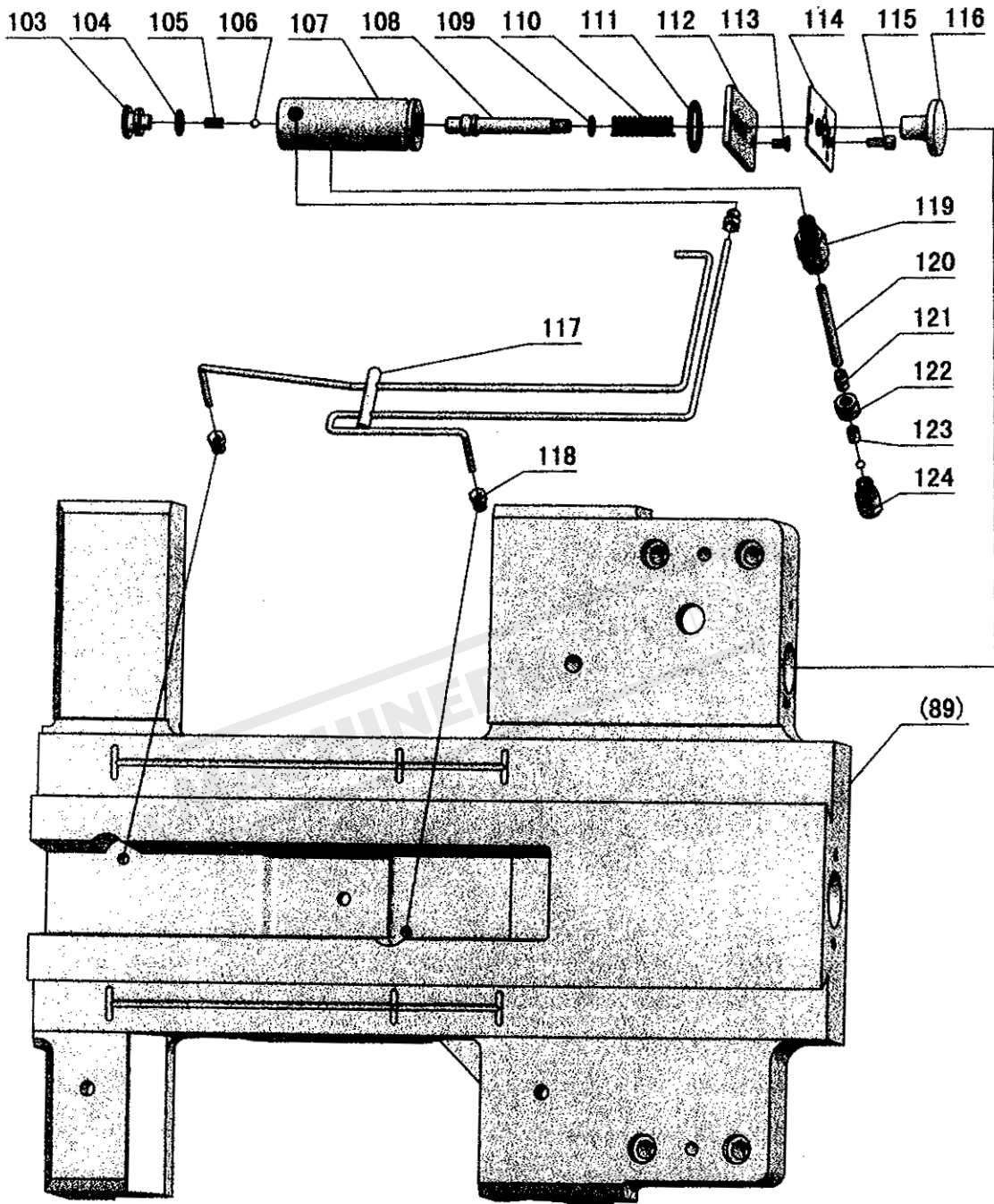

No.	Part No.	Name	Specification	Qty.
1	GB818-85	Screw	M4 × 12	16
2	C6251A-07-44	Case-Wiper		1
3	C6251A-07-43	Wiper		1
4	RUN6246-103056-1	Sleeve		1
5	GB2089-80	Spring	1 × 5 × 18	1
6	RUN6246-103058-2	Adjust Screw (Flat Type)		3
7	RUN6246-103057-2	Round Pin		1
8	C6251A-07-45	Four Way Tool Post		1
8	C6251A-07-46	Block-Tee (T Type)		1
9	GB83-88	Screw	M12 × 55	12
10	GB119-86	Pin	D6 × 60	3
11	GB77-85	Screw	M8 × 10	3
12	RUN6246-103062	Clamping Handle		1
13	RUN6246-103061	Clamping Handle		1
14	RUN6246-103060	Washer		1
15	GB301-84	Thrust Bearing	8104	1
16	RUN6246-103058-1	Sleeve (Flat Type)		1
17	C6251A-07-42	Tool Post Shaft (Flat Type)		1
17	C6251A-07-42-1	Tool Post Shaft (T Type)		1
18	GB77-85	Screw	M8 × 40	1
19	GB1155-79	Ball Cup	6	6
20	GB308-84	Steel Ball	1/4"	2
21	GB80-85	Screw	M8 × 10	2
22	C6251A-07-50	Compound Rest (Flat Type)		1
22	C6251A-07-50-1	Compound Rest (T Type)		1
23	RUN6246H-103043-1	Nut (Metric)		1
23	RUN6246H-103043-2	Nut (Inch)		1
24	RUN6246-103043	Screw-Compound Rest (Metric)		1
24	RUN6246-103043-3	Screw-Compound Rest (Inch)		1
25	GB77-85	Screw	M6 × 6	1
26	GB80-85	Screw	M5 × 8	1
27	GB879-86	Spring Pin	2 × 12	1
28	GB301-84	Thrust Bearing	8102	2
29	RUN6246-103044	Seat Compound Rest Screw		1
30	GB70-85	Screw	M6 × 20	2
31	RUN6246-103044-1	Nut		1
32	RUN6246-103045	Collar		1
33	RUN6246-103046-1	Dial-Compound Rest (Metric)		1
33	RUN6246-103046-2	Dial-Compound Rest (Inch)		1
34	RUN6246-103047-1	Wave Type Washer		1

No.	Part No.	Name	Specification	Qty.
35	RUN6246-103047	Nut		1
36	RUN6246-103048	Handle		1
37	RUN6246-103049	Handle		1
38	GB70-85	Screw	M6 × 10	3
39	GB70-85	Screw (C6251A)	M10 × 55	1
39	GB70-85	Screw (C6256A)	M10 × 80	1
40	RUN6246-103037	Screw		1
41	C6251A-07-51	Gib		1
42	GB70-85	Screw (C6251A)	M10 × 40	2
42	GB70-85	Screw (C6256A)	M10 × 65	2
43	C6251A-07-41	Swivel Table		1
43	C6256A-07-41	Swivel Table		1
44	GB80-85	Screw	M6 × 10	2
45	C6251A-07-39	Case-Wiper		1
46	C6251A-07-38	Wiper		1
47	RUN6246-103036	Screw		4
48	C6251A-07-02-1	Indicator Dial		1
49	RUN6246-103040	Nut		3
50	C6251A-07-02	Cover-Cross Sliding		1
51	GB79-85	Screw	M8 × 30	1
52	GB70-85	Socket Head Cap Screw	M6 × 35	3
53	RUN6246-103022-2	Key		1
54	C6251A-07-21Y	Cross Feed Screw (Inch)		1
54	C6251A-07-21	Cross Feed Screw (Metric)		1
55	RUN6141-103003	Nut (Metric)		1
55	RUN6141-103003-1	Nut (Inch)		1
56	C6251A-07-35	Gib		1
57	RUN6246-103004	Gib		1
58	GB301-84	Thrust Bearing	8101	2
59	RUN6141-103007	Bracket		1
60	RUN6246-103007-1	Nut		1
61	RUN6141-103105	Cover		1
62	RUN6246-103030A	Handle		1
63	GB70-85	Screw	M8 × 16	1
64	RUN6246-103029	Handle		1
65	RUN6246-103028	Nut		1
66	RUN6246-103025	Wave Type Washer		1
67	RUN6141-103027	Cross Feed Dial (Metric)		1
67	RUN6141-103027-1	Cross Feed Dial (Inch)		1
68	GB70-85	Socket Head Set Screw	M8 × 70	2

No.	Part No.	Name	Specification	Qty.
69	GB278-86	Screw	2 × 5	2
70	RUN460-105031	Plate		1
71	SF-1	Bearing	1810	2
72	GB118-86	Taper Pin	6 × 26	2
73	GB70-85	Screw	M8 × 20	6
74	GB70-85	Screw	M10 × 60	4
75	GB118-86	Taper Pin	8 × 60	2
76	C6251A-07-13	Case-Wiper		2
77	RUN6246-103026	Clutch-Dial		1
78	GB80-85	Screw	M6 × 8	1
79	C6251A-07-11	Wiper		1
80	RUN6246-103077	Bolt		1
81	C6251A-07-23	Bracket		1
82	GB1155-79	Ball Cup	8	1
83	C6251A-07-10	Case-Wiper		2
84	C6251A-07-08	Wiper		1
85	C6251A-07-22	Cross Feed Pinion		1
86	GB1567-79	Key	8 × 12	1
87	GB894-1-86	Snap Ring	24	2
88	C6251-A-07-22-2	Gear		1
89	C6251A-07-01	Saddle		1
90	RUN6246-103031-1	Plate		1
91	RUN6246-103031	Plug-Oil Inlet		1
92	C6251A-07-20	Gib-Front		1
93	RUN6246-103019	Clamp-Carriage		1
94	GB70-85	Screw	M6 × 20	1
95	C6251A-07-18	Gib-Left-Front		1
96	C6251A-07-12	Wiper		1
97	C6251A-07-15	Gib		1
98	GB70-85	Screw	M5 × 10	4
99	RUN6141-103016-1	Baffle		2
100	C6251A-07-16	Holder Gib		1
101	GB70-85	Screw	M8 × 30	4
102	C6251A-07-09	Wiper		1
103	RUN6246-103070	Oil Plug		1
104	GB1235-76	O-Ring	16 × 2.4	1
105	GB2089-80	Spring	0.5 × 4.5 × 16	1
106	GB308-84	Steel Ball	φ 5	2
107	RUN6246-103063	Body Pump		1
108	RUN6246-103064	Piston Rod		1

No.	Part No.	Name	Specification	Qty.
109	GB3452.1-82	O-Ring	9 × 1.8	1
110	RUN6246-103065	Spring		1
111	GB1235-76	O-Ring	32 × 3.1	1
112	RUN6246-103066	Bottom Board		1
113	GB68-85	Screw	M5 × 10	2
114	RUN6246-103068	Plate		1
115	GB70-85	Screw	M5 × 12	2
116	RUN6246-103067	Plug		1
117	RUN6141-103106	Vitta welding		1
118		Tube Fitting	Z 1/8" × φ 4	3
119		Tube Fitting	Z 1/8" × φ 6	1
120		Brass Tube	φ 6 × 170	1
121	RUN6246-103071	Tube Fitting		1
122	RUN6246-103072	Nut		1
123	RUN6246-103073-2	Sleeve		1
124	RUN6246-103073-1	One Way Valve Ass		1

MACHINERYHOUSE

Apron

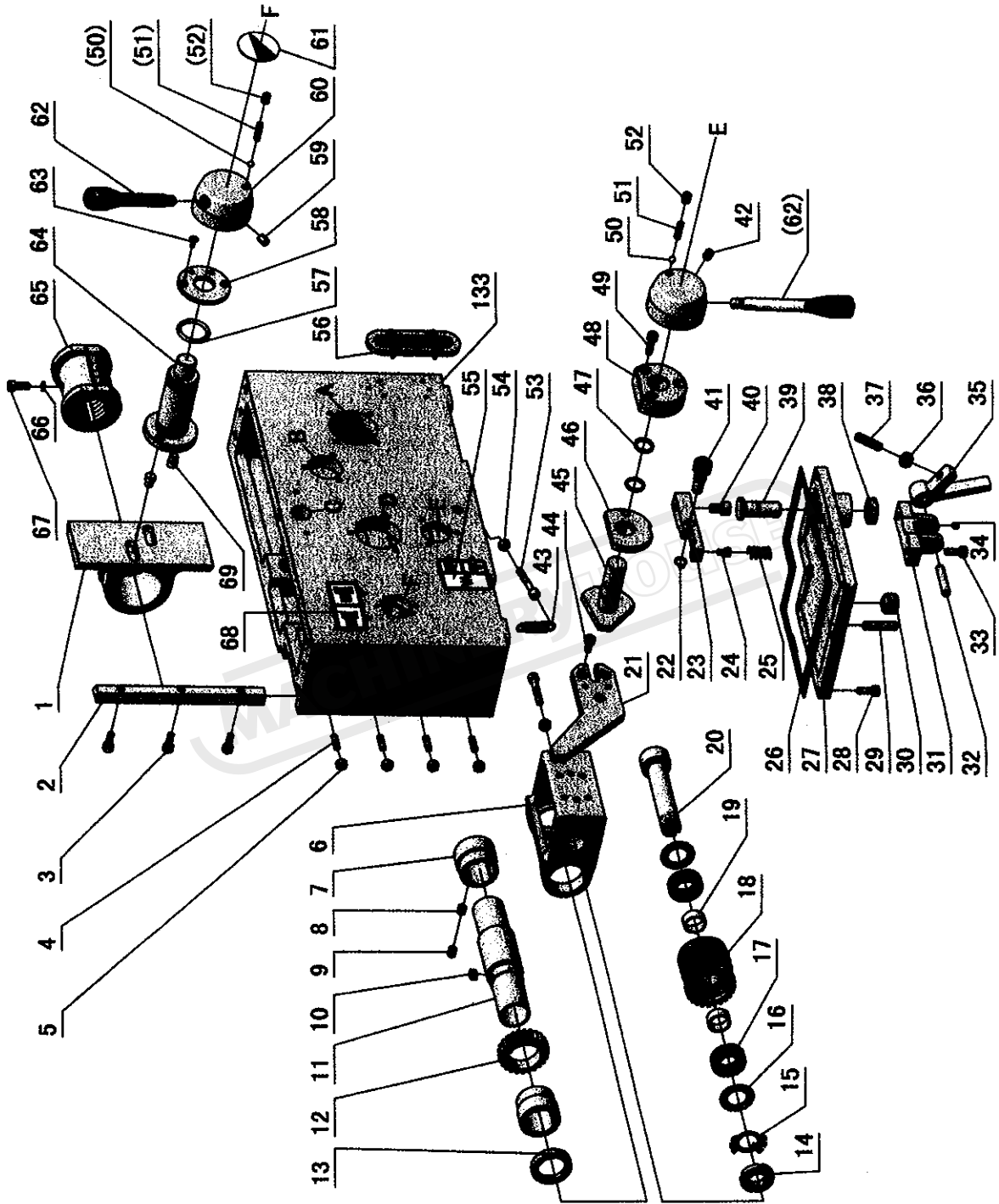

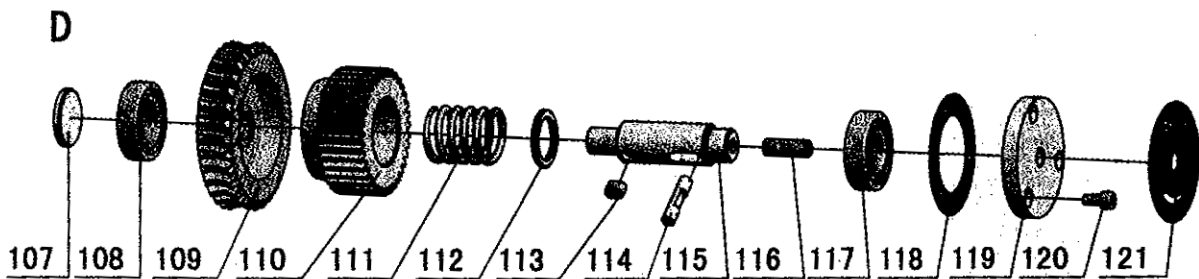
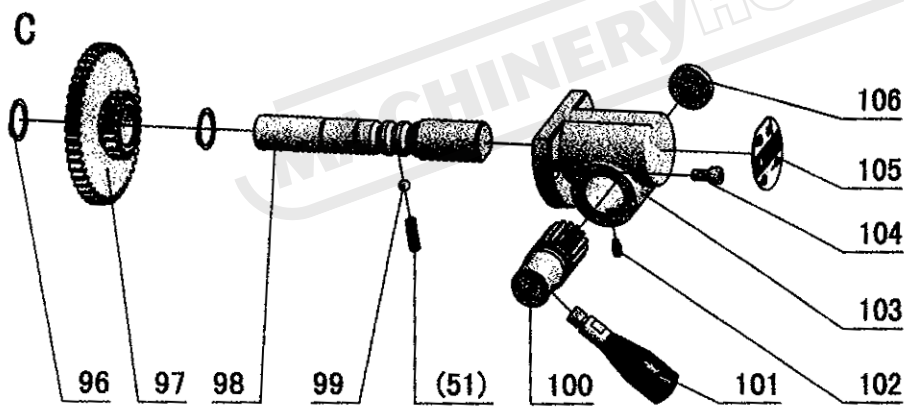
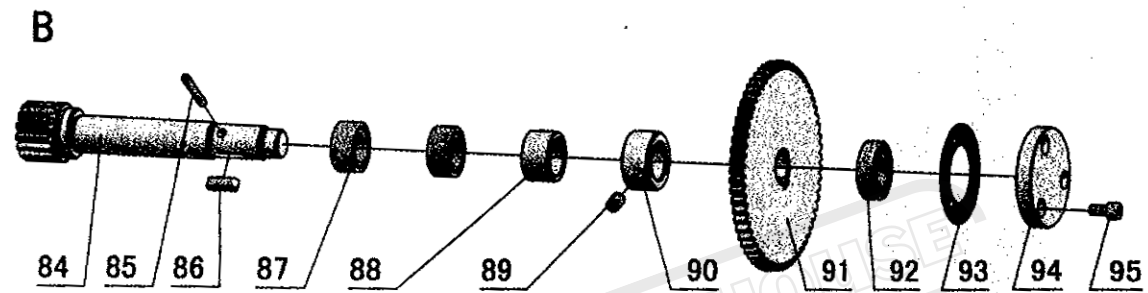
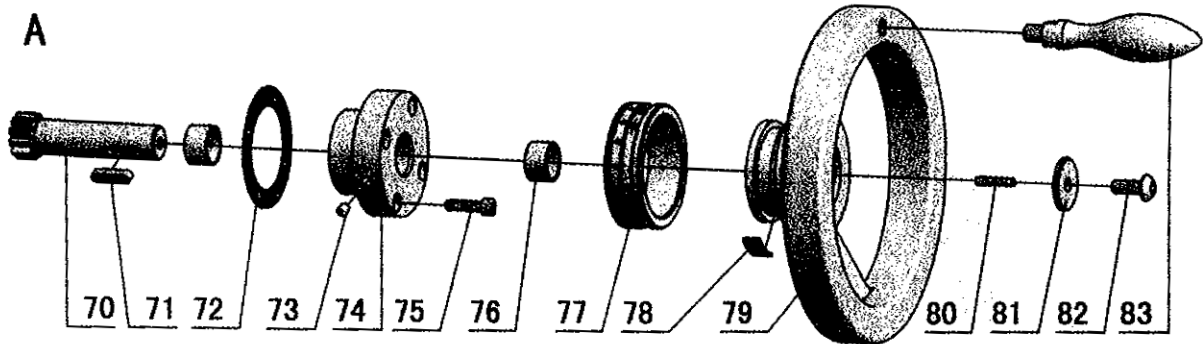

I

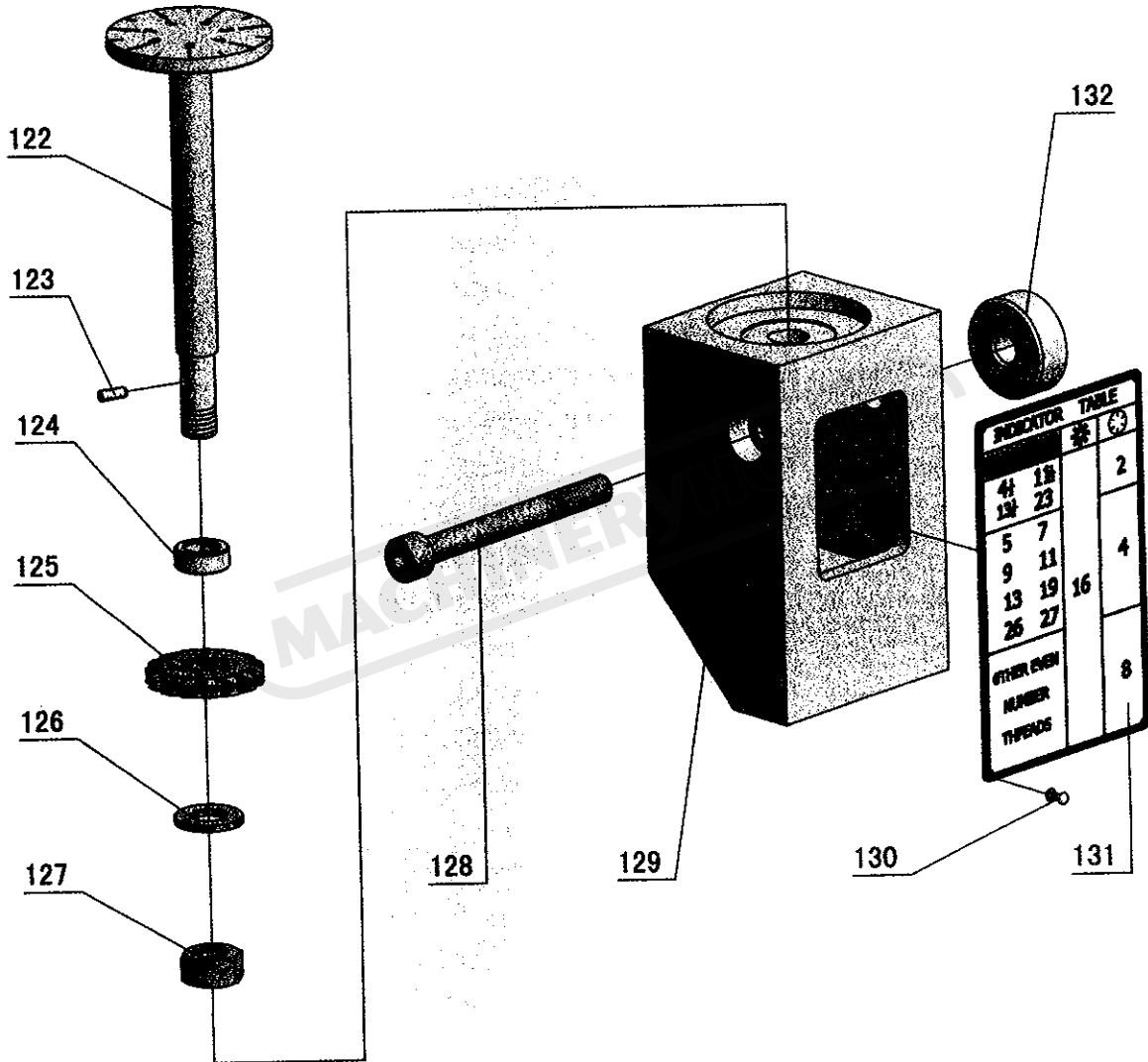

No.	Part No.	NAME	Specification	Qty
1	RUN460-104003A	LEAD NUT ASSY (RIGHT		1
2	RUN460-104002	GIB		1
3	GB70-85	SCREW	M6 × 16	3
4	GB80-85	SCREW	M6 × 20	4
5	GB6170-86	NUT	M6	4
6	RUN460-104018-01	SEAT-WORM		1
7	RUN460-104015	BUSHING		2
8	GB80-85	SCREW	M8 × 10	2
9	GB77-85	SCREW	M8 × 10	2
10	GB1096-79	KEY	6 × 12	1
11	RUN460-104016	SLEEVE-FEED ROD		1
12	RUN460-104017	GEAR		1
13		OIL SEAL	TC32 × 42 × 8	2
14	GB812-88	NUT	M20 × 1.5	1
15	GB858-88	NUT	20	1
16	RUN6246-104020-1	WASHER		2
17	GB301-84	THRUST BEARING	8104	2
18	RUN460-104020	WORM GEAR		1
19	CB85-2010	SET	20	2
20	RUN6246-104019	SHAFT		1
21	RUN460-104023-01	SAFE DEVICE BLOCK		1
21	RUN460-104023-02	SAFE DEVICE BLOCK (LEFT		1
22	GB894.1-86	SNAP RING	10	1
23	RUN460-104030	LEVER		1
24	GB70-85	SCREW	M5 × 8	1
25	RUN460-104032	SPRING		1
26	RUN460-104011	BOTTOM COVER		1
27	RUN460-104011-1	SEALED MAT		1
28	GB70-85	SCREW	M6 × 16	9
29	GB77-85	SCREW	M6 × 35	1
30	G38-3A	OIL PLUG	Z 3/8"	1
31	RUN460-104012	BRACKET		1
32	GB119-86	PIN	B8 × 40	1
33	GB70-85	SCREW	M6 × 16	2
34	GB80-85	SCREW	M6 × 6	1
35	RUN460-104014	LEVER		1
36	GB77-85	SCREW	M8 × 30	1
37	GB6170-86	NUT	M8	1
38		OIL SEAL	TC15 × 25 × 7	1
39	RUN460-104010	PIN		1

No.	Part No.	NAME	Specification	Qty
40	GB70-85	SCREW	M8 × 12	1
41	RUN460-104031	SCREW		1
42	GB80-85	SCREW	M8 × 10	1
43	RUN460-104022-01	SPRING		1
44	GB70-85	SCREW	M6 × 12	3
45	RUN460-104026-01	SHAFT (RIGHT HAND)		1
46	RUN460-104027	BUFFER		1
47		O-RING	20 × 24	2
48	RUN460-104028	SLEEVE		1
49	GB70-85	SCREW	M6 × 20	3
50	GB308-84	STEEL BALL	1/4"	2
51	RUN6246-101066	SPRING		3
52	GB77-85	SCREW	M8 × 10	2
53	GB70-85	SCREW	M6 × 35	2
54	GB6170-86	NUT	M6	2
55	RUN6246-104074	KNOB (RIGHT HAND)		1
56	RUN460-104068	OIL SIGHT		1
57	GB1235-76	O-RING	32 × 35	2
58	RUN6246-104007-01	SHAFT SLEEVE (RIGHT		1
58	RUN6246-104007-02	SHAFT SLEEVE (LEFT		1
59	GB80-85	SCREW	M8 × 10	1
60	RUN460-104007-02	SHAFT SLEEVE (RIGHT		1
61	RUN6246-101099	PLATE		1
62	RUN460-104008	LEVER		2
63	GB819-85	SCREW	M4 × 10	2
64	RUN460-104006-01	SHAFT (RIGHT HAND)		1
64	RUN460-104006-02	SHAFT (LEFT HAND)		1
65	C6251A-06-01	HAFT NUT (METRIC)		1
65	C6251A-06-01Y	HAFT NUT (INCH)		1
66	GB93-87	SPRING PIN	6	2
67	GB70-85	SCREW	M6 × 16	2
68	RUN460-104073	PLATE (RIGHT HAND)		1
69	RUN460-104005	KEY		2
70	RUN460-104051	SHAFT		1
71	GB1096-79	KEY	6 × 25	1
72	RUN460-104052-1	SEALED MAT		1
73	GB1155-89	BALL CUP	6	1
74	RUN460-104052	SEAT		1
75	GB70-85	SCREW	M6 × 25	4
76	SF-1	BEARING	2010	2

No.	Part No.	NAME	Specification	Qty
77	RUN460-104054-01	DIAL-RACK (METRIC)		1
78	Q67-4-33	SPRING	80	1
79	RUN460-104055	HAND WHEEL		1
80	GB77-85	SCREW	M4 × 20	1
81	RUN460-104057	WASHER		1
82	RUN6246-101088	SCREW		1
83	RUN460-104056A	HANDLE		1
84	RUN460-104047	PINON		1
85	GB879-86	PIN	5 × 35	1
86	GB1096-79	KEY	6 × 20	1
87	GB5801-86	NEEDLE BEARING	4644903	2
88	RUN460-104053	SLEEVE		1
89	GB80-85	SCREW	M8 × 12	1
90	RUN460-104048	SPACER		1
91	RUN460-104049	GEAR		1
92	GB278-89	BALL BEARING	80103	1
93	RUN460-104050-1	SEALED MAT		1
94	RUN460-104050	COVER		1
95	GB70-85	SCREW	M6 × 12	3
96	GB894.1-86	SNAP RING	20	2
97	RUN460-104041	GEAR		1
98	RUN460-104042	SHAFT		1
99	GB308-84	STEEL BALL	7/32"	1
100	RUN460-104044	CHANGE GEAR		1
101	RUN460-104045	HANDLE LEVER		1
102	GB79-85	SCREW	M5 × 10	1
103	RUN460-104043	CHANGE SLEEVE		1
104	GB70-85	SCREW	M6 × 12	2
105	RUN460-104077	PLATE		1
106	RUN460-104043-1	PLUG		1
107	RUN460-104036-1	COVER		1
108	GB278-89	BALL BEARING	180105	1
109	RUN460-104034	WORM GEAR		1
110	RUN460-104035	GEAR		1
111	RUN460-104038	SPRING		1
112	RUN460-104039	SPACER		1
113	GB1096-79	KEY	8 × 12	1
114	RUN460-104037	PIN		1
115	RUN460-104036	COVER		1
116	GB77-85	SCREW		1

No.	Part No.	NAME	Specification	Qty
117	GB278-89	BALL BEARING	80204	1
118	RUN460-104040-1	SEALED MAT		1
119	RUN460-104040	COVER		1
120	GB70-85	SCREW	M6 × 12	3
121	RUN6246-104072	PLATE		1
122	RUN460-104059B	DIAL INDICATOR SHAFT		1
123	GB879-86	PIN	3 × 8	1
124	RUN460-104046	SPACER		1
125	RUN460-104060	GEAR (METRIC)		1
126	GB97.2-85	WASHER	10	1
127	GB6170-86	NUT	M10	1
128	GB70-85	SCREW	M8 × 85	1
129	RUN460-104058	THREAD DIAL BODY		1
130	GB827-86	RIVET	2 × 5	10
131	RUN6246-104071	INDICATOR DIAL (METRIC)		1
132	RUN460-104024	SPACER		1
133	RUN6246-104001A	APRON (RIGHT HAND)		1
133	RUN460-104001B	APRON (LEFT HAND)		1

Tailstock

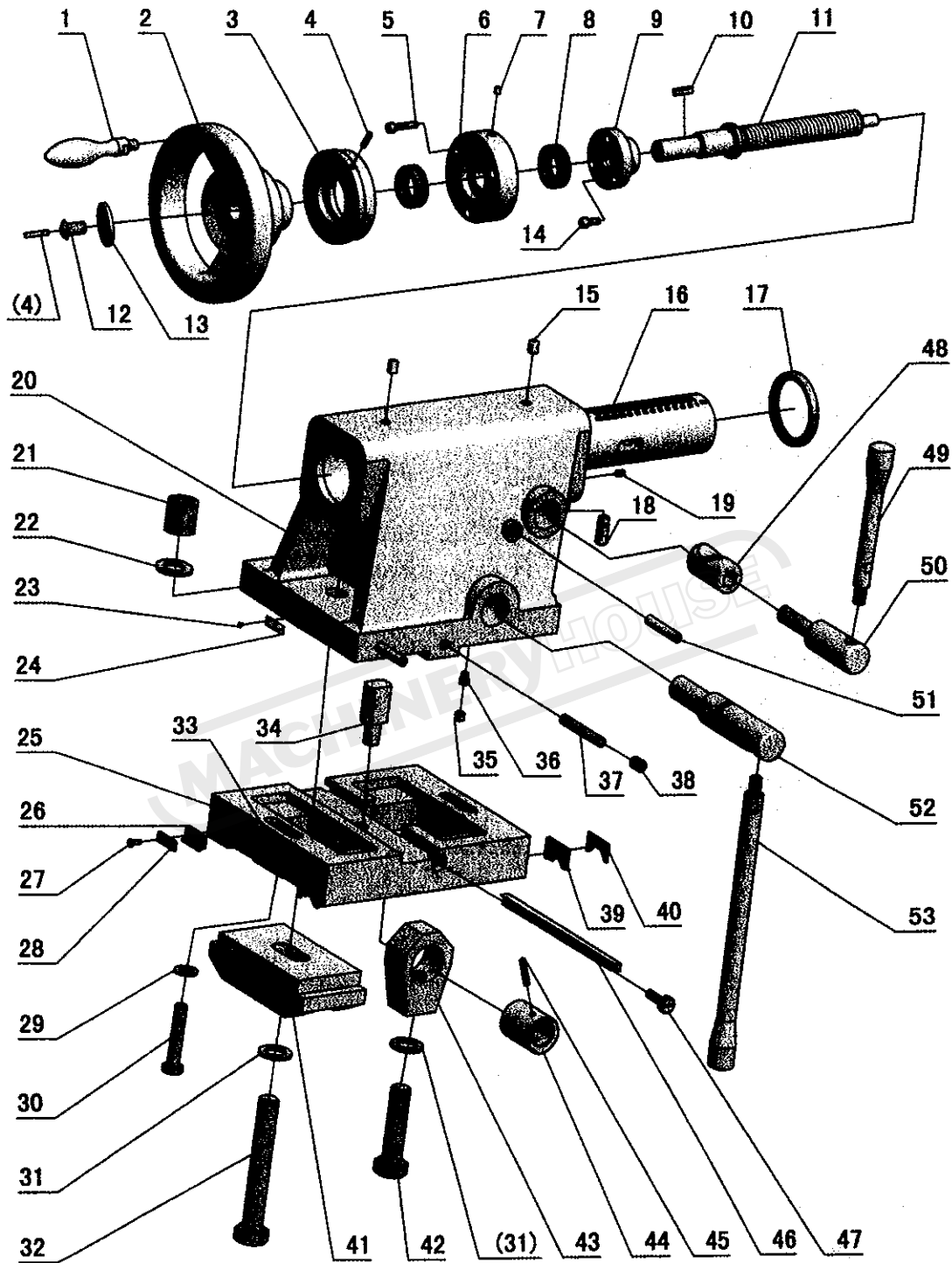

No.	Part No.	Name	Specification	Qty.
1	RUN460-104056A	Handle		1
2	C6246B-105010	Handle Wheel		1
3	C6251A-08A-03	Dial-Feed (Metric)		1
3	C6251A-08A-03Y	Dial-Feed (Inch)		1
4	GB80-85	Screw	M5 × 25	2
5	GB70-85	Screw	M6 × 35	3
6	C6251A-08A-02	Cap-Body End		1
7	GB1155-79	Ball Cup	6	1
8	GB301-84	Thrust Bearing	8105	2
9	C6246B-105005	Feed Nut (Metric)		1
9	C6246B-105005-1	Feed Nut (Inch)		1
10	GB1096-79	Key	6 × 16	1
11	C6251A-08A-01	Feed Screw (Metric)		1
11	C6251A-08A-01Y	Feed Screw (Inch)		1
12	C6266-08-18	Screw		1
13	C6266-08-19	Washer		1
14	GB70-85	Screw	M6 × 16	4
15	GB1155-79	Ball Cup	10	2
16	C6246B-105003	Tailstock Sleeve		1
17	HG4-692-67	Oil-Seal	PD75 × 95 × 12	1
18	C6246B-105030	Pin Shaft		1
19	GB80-85	Screw	M6 × 10	1
20	C6251A-08-01	Tailstock Body		1
21	GB56-88	Nut	M20	1
22	GB95-85	Washer	20	1
23	RUN460-105031	Plate		1
24	GB827-86	Rivet	2 × 5	4
25	C6251A-08-02	Bottom Tailstock		1
25	C6256A-08-02	Bottom Tailstock		1
26	C6251A-08-09	Wiper		2
27	GB818-85	Cross Recessed Head Screw	M4 × 12	8
28	C6251A-08-08	Case-Wiper		2
29	GB95-85	Washer	12	2
30	GB5782-86	Screw (C6251A)	M12 × 70	2
30	GB5782-86	Screw (C6256A)	M12 × 90	2
31	GB848-85	Washer	20	1
32	GB37-88	Bolt (C6251A)	M20 × 150	1
32	GB37-88	Bolt (C6256A)	M20 × 175	1
33	RUN460-105032	Plate		1
34	RUN460-105017	Block-Adjusting		1

No.	Part No.	Name	Specification	Qty.
35	GB77-86	Screw	M10 × 8	1
36	GB79-85	Screw	M10 × 12	1
37	GB119-86	Pin Shaft	12 × 85	2
38	GB80-85	Screw	M16 × 20	2
39	C6251A-08-06	Wiper		2
40	C6251A-08-07	Case-Wiper		2
41	C6251A-08-03	Clamping Handle		2
42	GB5782-86	Screw (C6251A)	M20 × 100	1
42	GB5782-86	Screw (C6256A)	M20 × 125	1
43	RUN460-105018	Bracket		1
44	RUN460-105028	Eccentric Block		1
45	GB879-86	Spring Pin	6 × 36	1
46	C6246B-105012	Taper Gib Strip		1
47	RUN460-105020	Screw		1
48	C6246B-105021	Block Clamp		1
49	RUN460-105004	Lead Screw		1
50	C6251A-08-05	Shaft		1
51	RUN6246-105007	Screw-Brake		2
52	C6251A-08-04	Shaft		1
53	RUN460-105006	Lead Screw		1

Bed Assembly

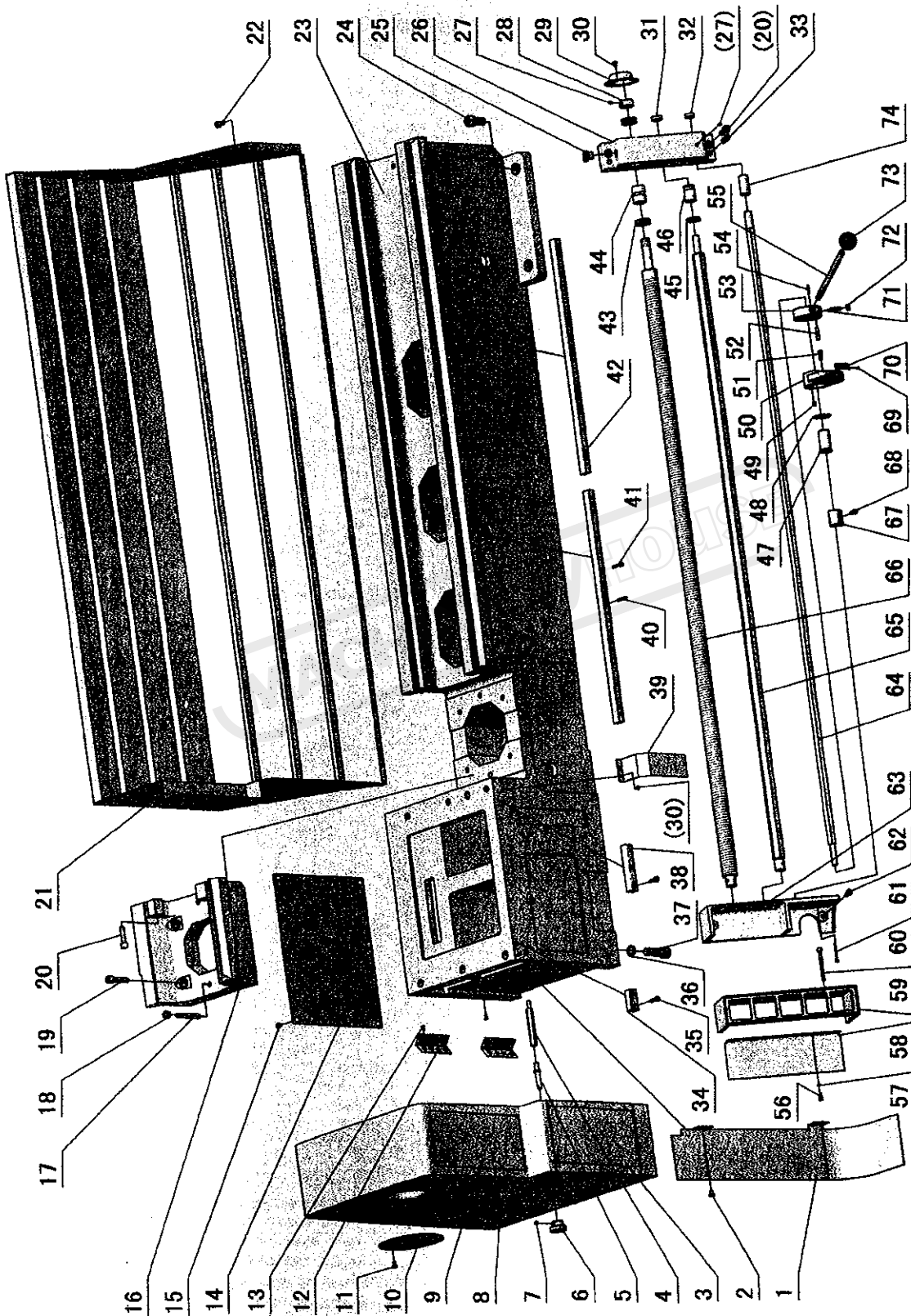

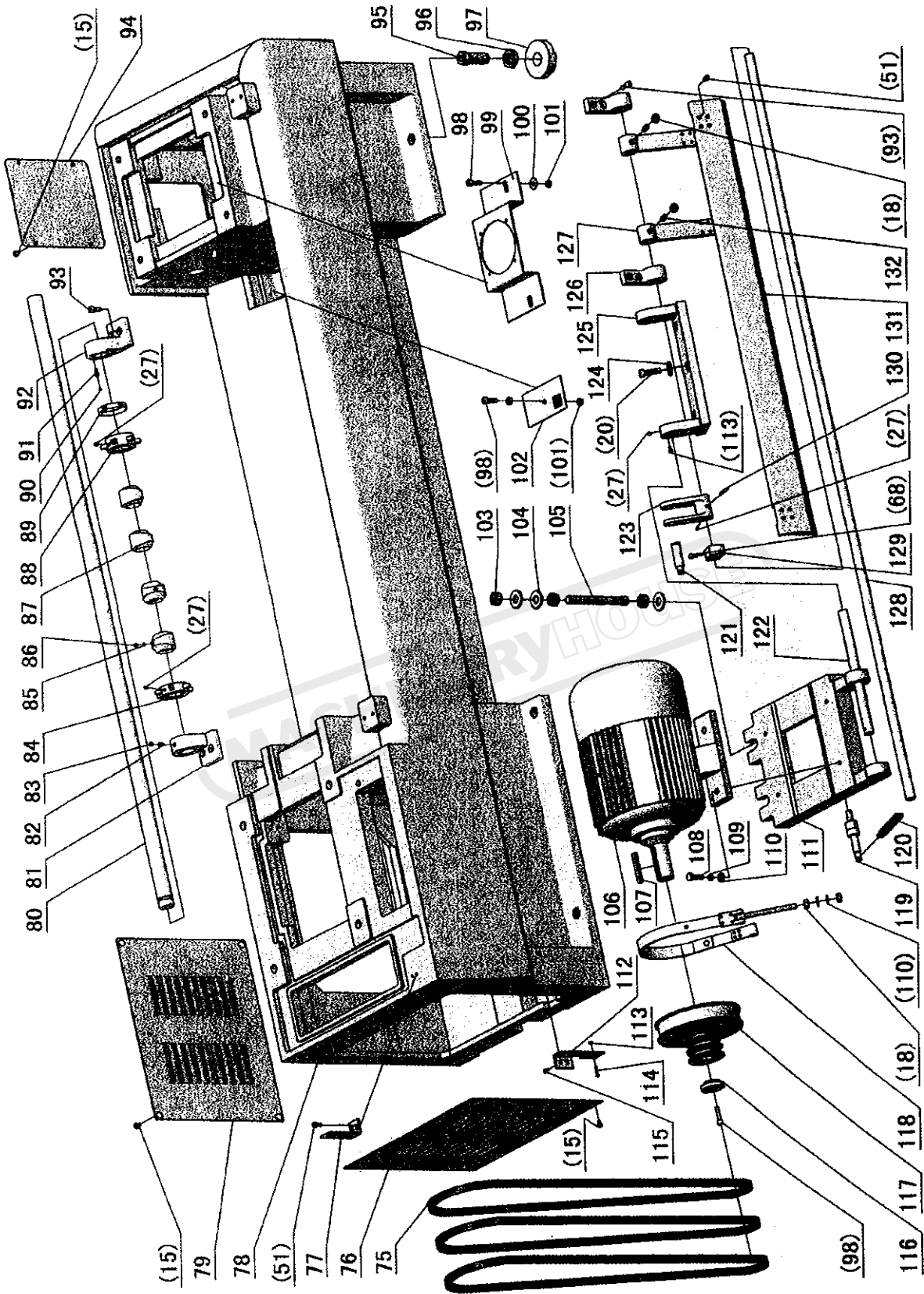

(Metric)

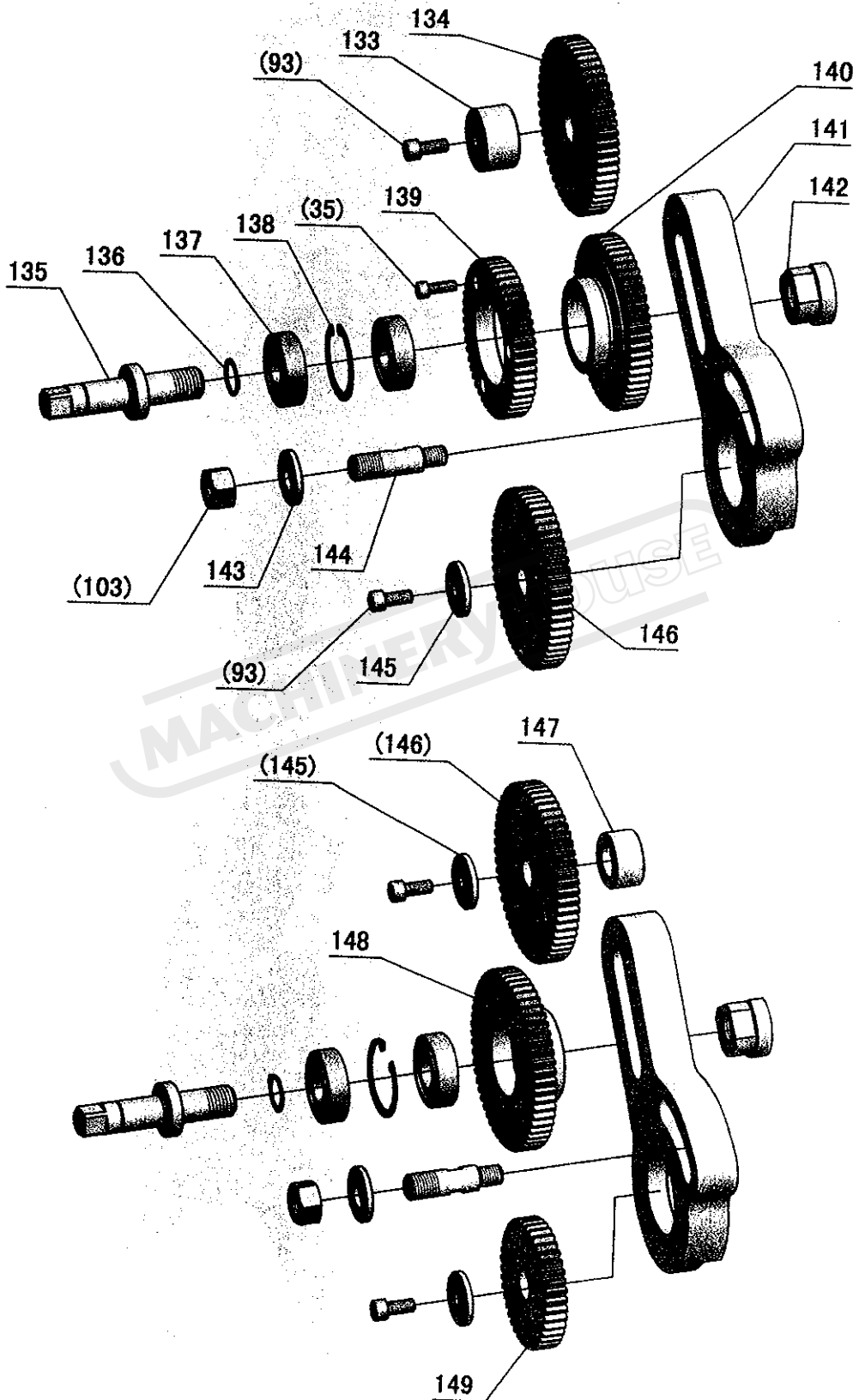

(Inch)

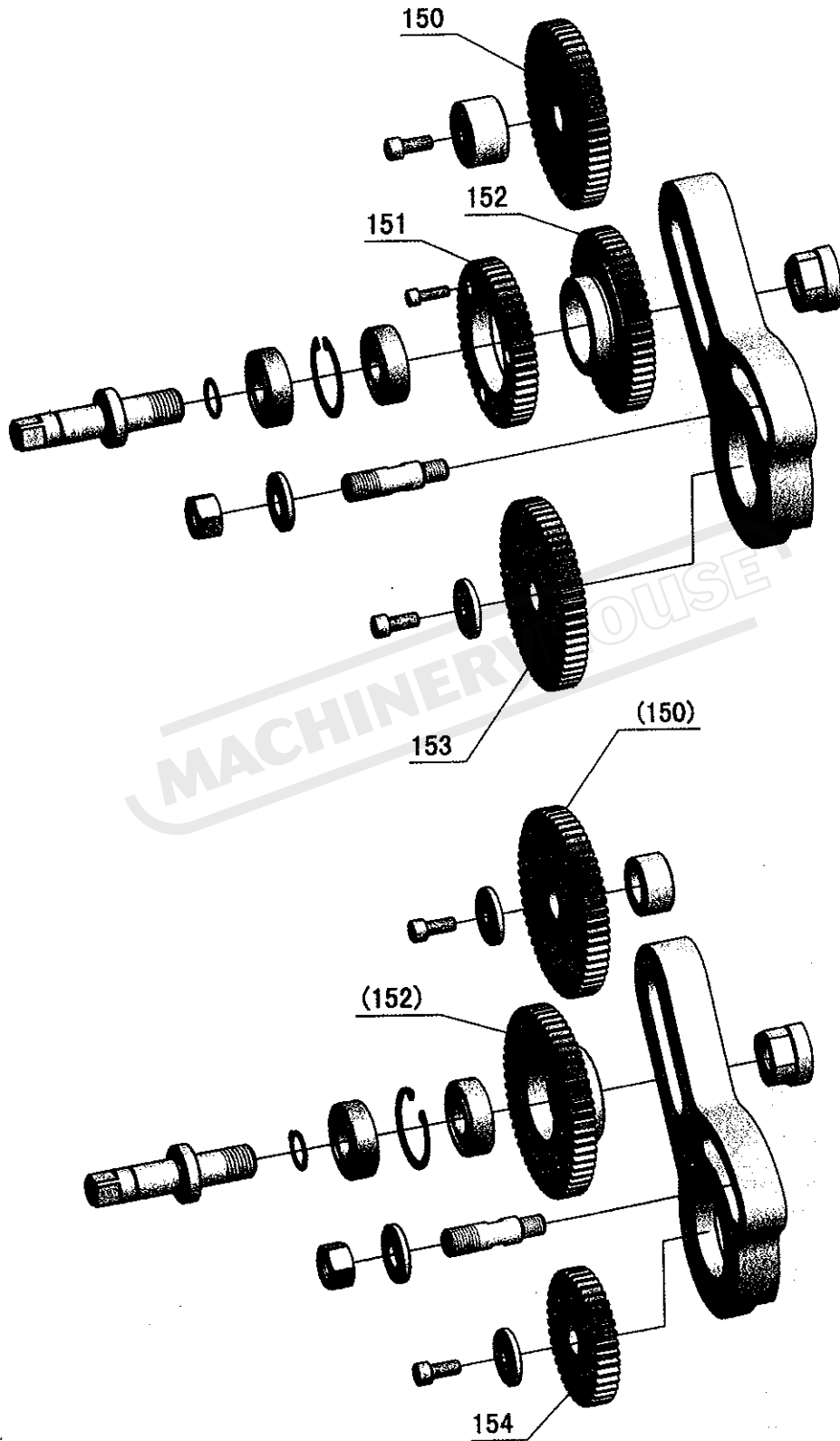

No.	Part No.	Name	Specification	Qty.
1	C6251A-01-20	Oil Guard		1
1	C6256A-01-20	Oil Guard		1
2	GB70-85	Screw	M6 × 10	2
3	RUN6246-108094	Plate		1
4	C6251A-05-12	Screw		1
5	RUN6246-108074	Screw		1
6	RUN6246-108073	Nut		1
7	GB79-85	Screw	M6 × 8	1
8	C6251A-04-02	Cover-End		1
8	C6256A-04-02	Cover-End		1
9	C6251A-04-04	Plate (Metric)		1
9	C6251A-04-04Y	Plate (Inch)		1
10	C6251A-04-05	Cover		1
11	GB/T70.2-2000	Screw	M6 × 10	1
12	GB7277-87	Hinge	100	2
13	GB68-85	Screw	M5 × 10	16
14	RUN6246-106071	Electric Cover		1
15	GB818-85	Screw	M6 × 10	16
16	C6251A-01-02	Bed Gap		1
17	GB118-86	Pin	10 × 70	2
18	GB6170-86	Nut	M10	6
19	GB70-85	Screw	M12 × 50	4
20	GB70-85	Screw	M10 × 40	7
21	C6251A-01-15A	Guard Assembly 1000		1
21	RUN6246-106072B	Guard Assembly 1500		1
21	RUN6246-106072C	Guard Assembly 2000		1
21	C6251A-01-15D	Guard Assembly 3000		1
22	GB70-85	Screw	M8 × 16	4
23	C6251A-01-01	Bed 1000		1
23	C6251A-01-01-1	Bed 1500		1
23	C6251A-01-01-2	Bed 2000		1
23	C6251A-01-01-5	Bed 3000		1
24	GB70-85	Screw	M16 × 35	4
25	RUN6246-106010-4	Plug-Oil Inlet		1
26	C6251A-01-07	Bracket		1
27	GB80-85	Screw	M6 × 8	
28	C6251A-01-04	Nut		1
29	RUN6246-106031	Cover		1
30	GB818-85	Screw	M5 × 8	5
31	RUN6246-106010-1	Plug		1

No.	Part No.	Name	Specification	Qty.
32	RUN6246-106010-2	Plug		1
33	GB118-86	Taper Pin	10 × 45	2
34	C6251A-01-19	Block		1
35	GB70-85	Screw	M6 × 25	7
36	GB93-86	Spring Washer	16	4
37	GB70-85	Screw	M16 × 55	4
38	C6251A-01-18	Block		1
39	RUN6246-106009	Protection Cover		1
40	GB879-86	Spring Pin	5 × 30	6
41	GB70-85	Screw	M6 × 25	8
42	C6251A-01-05	Rack (Left Hand)		1
42	RUN6246-106005B	Rack		1
42	RUN6246-106005C	Rack		1
43	GB301-84	Thrust Bearing	8105	2
44	C6251A-01-07-1	Bush		1
45	RUN6246-106010-7	Spacer		1
46	RUN6246-106008	Bush		1
47	RUN6246-106056	Shaft Sleeve		1
48	RUN6246-106058	Washer		1
49	Q81-1	Spring	1 × 6 × 20	3
50	RUN6246-106059	Switch Bracket		1
51	GB70-85	Screw	M6 × 16	12
52	RUN6246-106055	Pin		1
53	RUN6246-106053	Bracket		1
54	GB879-86	Spring Pin	3 × 20	1
55	RUN6246-106057A	Lever		1
56	GB70-85	Screw	M5 × 10	2
57	GB93-87	Washer	5	2
58	RUN6141-106018-1	Cover		1
59	RUN6141-106018	Seat-Pilot Light		1
60	GB70-85	Screw	M6 × 70	2
61	GB70-85	Screw	M4 × 40	2
62	GB70-85	Screw	M8 × 25	2
63	RUN6246-106016	Seat-Switch		1
64	C6251A-01-09	Started Rod 1000		1
64	C6251A-01-09-1	Started Rod 1500		1
64	C6251A-01-09-2	Started Rod 2000		1
64	C6251A-01-09-5	Started Rod 3000		1
65	C6251A-01-08	Feed Rod 1000		1
65	C6251A-01-08-1	Feed Rod 1500		1

No.	Part No.	Name	Specification	Qty.
65	C6251A-01-08-2	Feed Rod 2000		1
65	C6251A-01-08-5	Feed Rod 3000		1
66	C6251A-01-06	Lead Screw 1000 (Metric)		1
66	C6251A-01-06-1	Lead Screw 1500 (Metric)		1
66	C6251A-01-06-2	Lead Screw 2000 (Metric)		1
66	C6251A-01-06-5	Lead Screw 3000 (Metric)		1
66	C6251A-01-06Y	Lead Screw 1000 (Inch)		1
66	C6251A-01-06Y-1	Lead Screw 1500 (Inch)		1
66	C6251A-01-06Y-2	Lead Screw 2000 (Inch)		1
66	C6251A-01-06Y-5	Lead Screw 3000 (Inch)		1
67	CM6233-2055	Cam		1
68	GB70-85	Screw	M6 × 12	2
69	GB827-86	Screw	2 × 5	2
70	RUN6246-106089	Plate		1
71	GB79-85	Screw	M8 × 30	2
72	GB6170-86	Nut	M8	2
73	Z16-1	Lever Bush	M12 × 40	1
74	RUN6246-106014	Bush		1
75	GB1171-74	Belt (C6251A)	B76(60Hz)	1
75	GB1171-74	Belt (C6256A)	B78(60Hz)	1
75	GB1171-74	Belt (C6251A)	B77(50Hz)	1
75	GB1171-74	Belt (C6256A)	B79(50Hz)	1
76	C6251A-01-11	Cover Motor Seat		1
77	RUN6246-108078	Limited Switch Seat		1
78	C6251A-01-03	Stand 1000		1
78	C6251A-01-03-1	Stand 1500		1
78	C6251A-01-03-2	Stand 2000		1
78	C6251A-01-03-5	Stand 3000		1
79	RUN6246-106028-1	Cover Motor Seat		1
80	C6251A-01-10	Auto Stopping Rod 1000		1
80	C6251A-01-10-1	Auto Stopping Rod 1500		1
80	C6251A-01-10-2	Auto Stopping Rod 2000		1
80	C6251A-01-10-5	Auto Stopping Rod 3000		1
81	RUN6141-106024	Bracket		1
82	GB79-85	Screw	M8 × 12	1
83	GB77-85	Screw	M8 × 6	1
84	RUN6246-106019-1	Star Type Ring		1
85	RUN6246-106020-1	Shoe Clamp		4
86	GB80-85	Screw	M8 × 6	4
87	RUN6246-106020	Cam		4

No.	Part No.	Name	Specification	Qty.
88	RUN6246-106019-2	Star Type Ring		1
89	RUN6246-106019-5	Plate		1
90	GB308-84	Steel Ball	6	1
91	Q81-1	Spring	1 × 5 × 25	1
92	RUN6141-106025	Bracket		1
93	GB70-85	Screw	M8 × 20	10
94	C6251A-01-12	Pump Hole Cover		1
95	RUN6246-106029	Bolt		6
96	GB6173-86	Nut	M24 × 2	6
97	RUN6246-106069	Block-Leveling		6
98	GB70-85	Screw	M8 × 30	4
99	C6251A-01-17	Coolant Pump Seat 1000		1
99	C6251A-01-17	Coolant Pump Seat 1500		1
99	C6251A-01-17	Coolant Pump Seat2000		1
99	C6251A-01-17-5	Coolant Pump Seat 3000		1
100	GB96-85	Washer	8	2
101	GB6170-86	Nut	M8	4
102	RUN6246-106051	Screen		1
103	GB6170-86	Nut	M16	7
104	RUN6246-106079	Washer		6
105	RUN6246-106046	Screw		2
106	Y132M-4	Motor	7.5kw	1
107	GB1096C-79	Key	10 × 70	1
108	GB5782-86	Bolt	M10 × 35	4
109	GB93-87	Spring Washer	10	4
110	GB97.1-86	Washer	10	4
111	RUN6246-106034	Motor Seat		1
112	RUN6246-106091	Limited Switch Seat		1
113	GB6170-86	Nut	M4	2
114	GB818-85	Screw	M4 × 20	2
115	GB70-85	Screw	M5 × 8	3
116	RUN6141-106049a	Washer		1
117	RUN6141-106048a	Belt Pulley	60Hz	1
117	RUN6141-106048a-1	Belt Pulley	50Hz	1
118	RUN6246-106047	Belt-Brake		1
119	RUN6246-106050	Shaft		1
120	Q81-3	Spring	3 × 16 × 115	1
121	RUN6246-106039	Shaft		1
122	RUN6246-106044	Shaft		1
123	RUN6246-106040	Arm Brake		1

No.	Part No.	Name	Specification	Qty.
124	RUN6246-106097	Washer		3
125	RUN6246-106041	Bracket-Motor Seat		1
126	RUN6246-106036	Bracket		2
127	RUN6246-106042A	Arm		2
128	C6251A-01-14	Shaft 1000		1
128	C6251A-01-14-1	Shaft 1500		1
128	C6251A-01-14-2	Shaft 2000		1
128	C6251A-01-14-5	Shaft 3000		1
129	RUN6246-106037	Cam		1
130	GB879-86	Spring Pin	5 × 40	1
131	C6251A-01-13	Pedal-Brake 1000		1
131	C6251A-01-13-1	Pedal-Brake 1500		1
131	C6251A-01-13-2	Pedal-Brake 2000		1
131	C6251A-01-13-5	Pedal-Brake 3000		2
132	GB79-85	Screw	M10 × 25	2
133	RUN6141-108002	Spacer		1
134	C6251A-04-03	Gear	55T × M2.25	1
134	C6256A-04-03	Gear	55T × M2.5	1
135	RUN6141-108004	Bolt		1
136	GB894.1-86	Snap Ring	20	1
137	GB278-89	Ball Bearing	180204	2
138	GB893.1-86	Snap Ring	47	1
139	C6251A-05-10	Gear	49T × M2.25	1
139	C6256A-05-10	Gear	49T × M2.5	1
140	C6251A-05-11	Gear	54T × M2.25	1
140	C6256A-05-11	Gear	54T × M2.5	1
141	C6251A-05-08	Bracket		1
142	RUN6141-108005	Nut		1
143	RUN6141-108017	Washer		1
144	C6251A-05-01	Bolt		1
145	C6251A-05-09	Spacer		2
146	C6251A-05-07	Gear	56T × M2.25	1
146	C6256A-05-07	Gear	56T × M2.5	1
147	RUN6141-108015	Spacer		1
148	C6251A-05-11Y	Gear	57T × M2.25	1
148	C6256A-05-11Y	Gear	57T × M2.5	1
149	C6251A-15-01	Gear	40T × M2.25	1
149	C6256A-15-01	Gear	40T × M2.5	1
150	C6251A-04-03Y	Gear	48T × M2.25	1
150	C6256A-04-03Y	Gear	48T × M2.5	1

No.	Part No.	Name	Specification	Qty.
151	C6251A-15-02y	Gear	66T × M2.25	1
151	C6256A-15-02Y	Gear	66T × M2.5	1
152	C6251A-05-11Y	Gear	57T × M2.25	1
152	C6256A-05-11Y	Gear	57T × M2.5	1
153	C6251A-15-01y	Gear	42T × M2.25	1
153	C6256A-15-01Y	Gear	42T × M2.5	1
154	C6251A-05-07Y	Gear	57T × M2.25	1
154	C6256A-05-07Y	Gear	57T × M2.5	1

MACHINERYHOUSE

Steady Rest

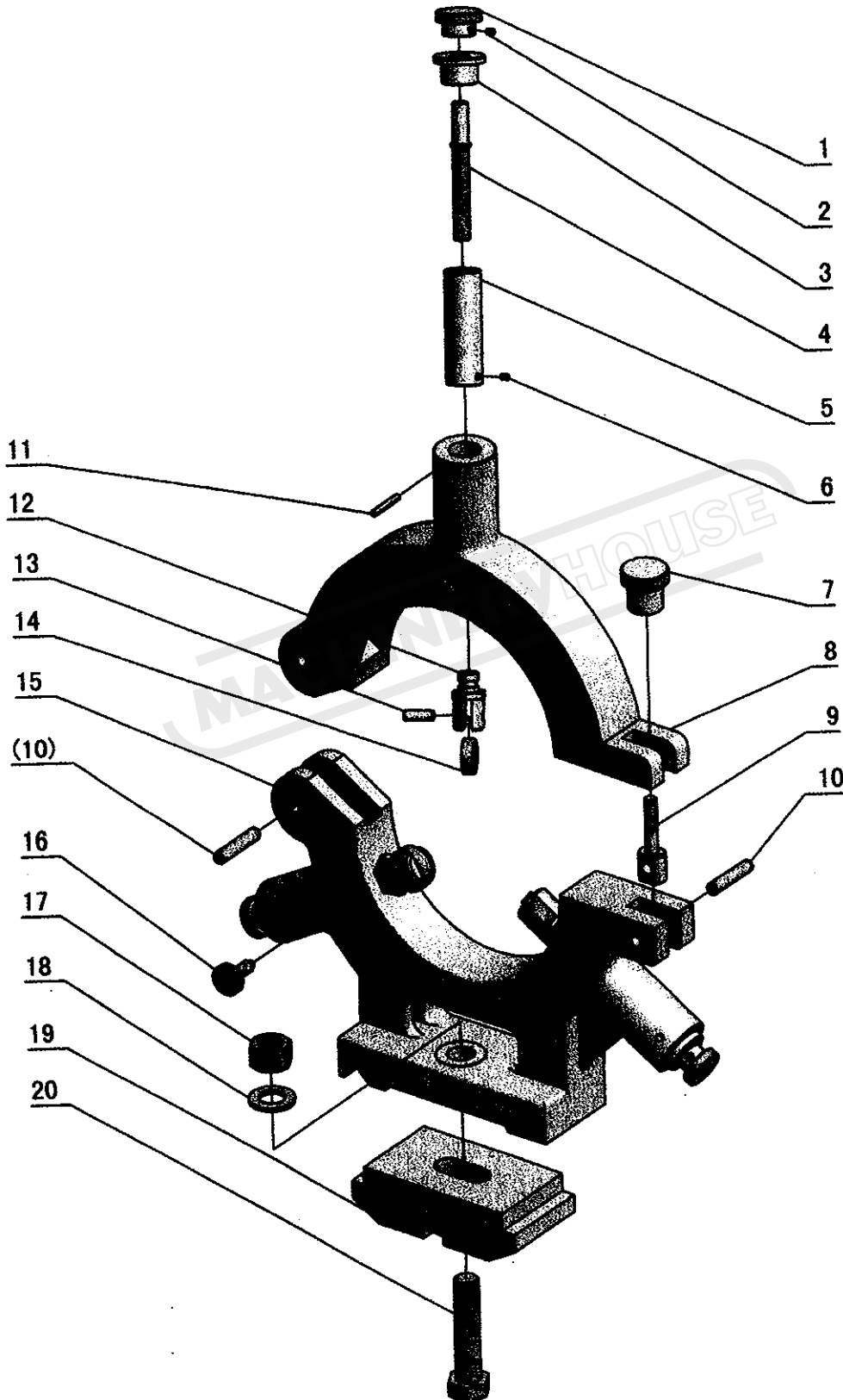

No.	Part No.	Name	Specification	Qty.
1	C6251A-10-08	Rotate Handle		3
2	GB78-85	Screw	M6 × 8	3
3	C6251A-10-07	Bush		3
4	C6251A-10-05	Screw Shaft		3
5	C6251A-10-04	Sleeve		3
6	GB77-85	Screw	M6 × 8	3
7	C6251A-10-09	Handle		1
8	C6251A-10-06	Upside Of Steady Rest		1
9	C6251A-10-10	Clamping Screw		1
10	GB119-86	Pin	10 × 60	2
11	GB879-86	Spring Pin	5 × 50	3
12	C6251A-10-02	Support Shaft		3
13	C6251A-10-03	Pin		3
14	GB279-88	Ball Bearing	180300	3
15	C6251A-10-01	Downside Of Steady Rest		1
15	C6256A-10-01	Downside Of Steady Rest		1
16	RUN6246-110018	Limited Screw		3
17	GB55-88	Nut	M20	1
18	GB97.2-85	Washer	20	1
19	C6251A-08-03	Clamping Bracket		1
20	GB37-88	Bolt	M20 × 110	1

Follow Rest

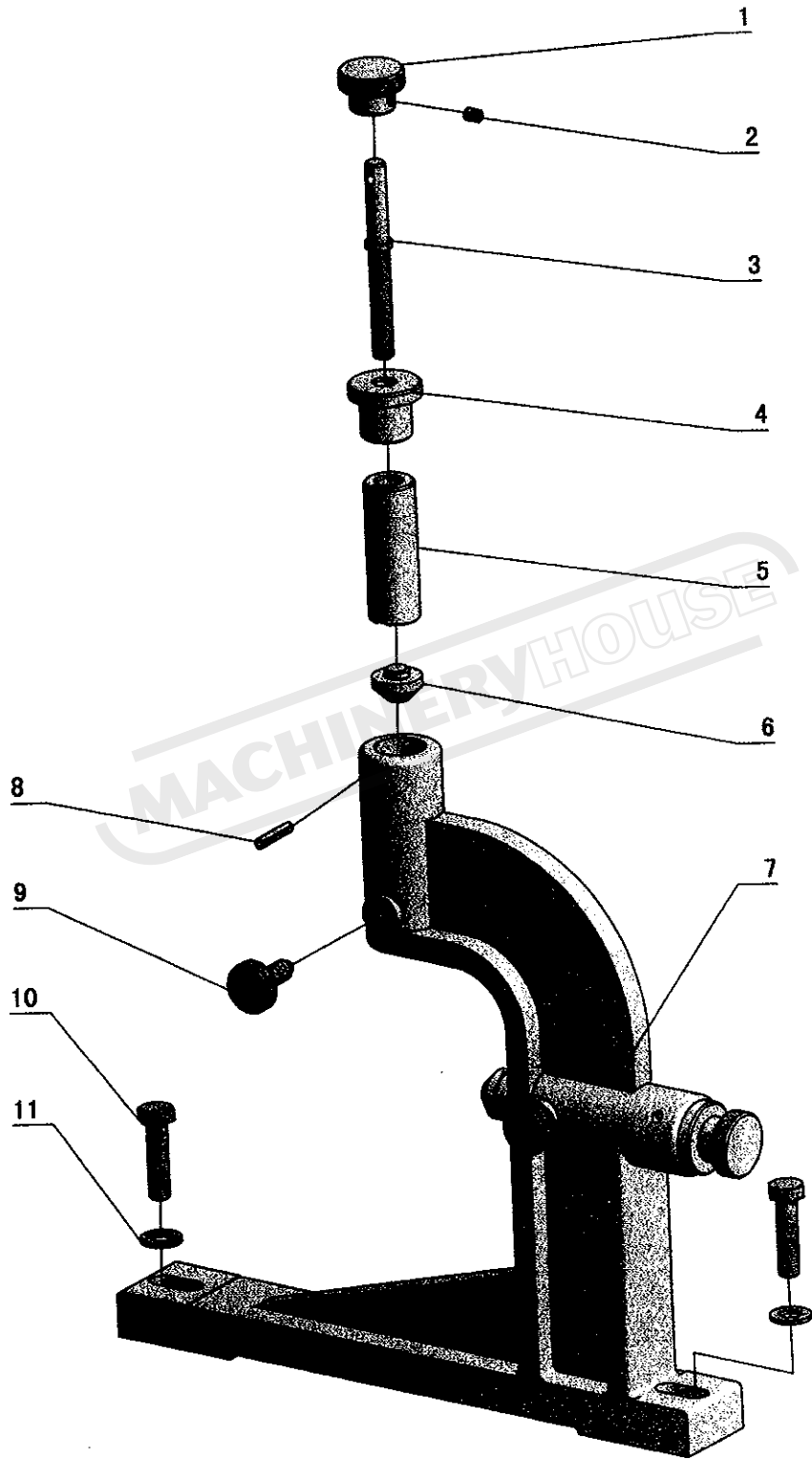

No.	Part No.	Name	Specification	Qty.
1	RUN6246-110019	Rotate Handle		2
2	GB78-85	Screw		2
3	C6251A-10-11	Follow Rest		1
3	C6256A-10-11	Follow Rest		1
4	RUN6246-110004	Bush		2
5	RUN6246-110016	Sleeve		2
6	RUN6246-110024	Bracket		2
7	RUN6141-110005	Follow Rest (C6241)		1
7	RUN6246H-110005	Follow Rest (C6246h)		1
8	GB879-86	Spring Pin	5 × 26	2
9	RUN6246-110018	Limited Screw		2
10	GB5782-86	Bolt	M10 × 40	2
11	GB97.1-85	Washer		2

MACHINERYHOUSE

Speed-move Device

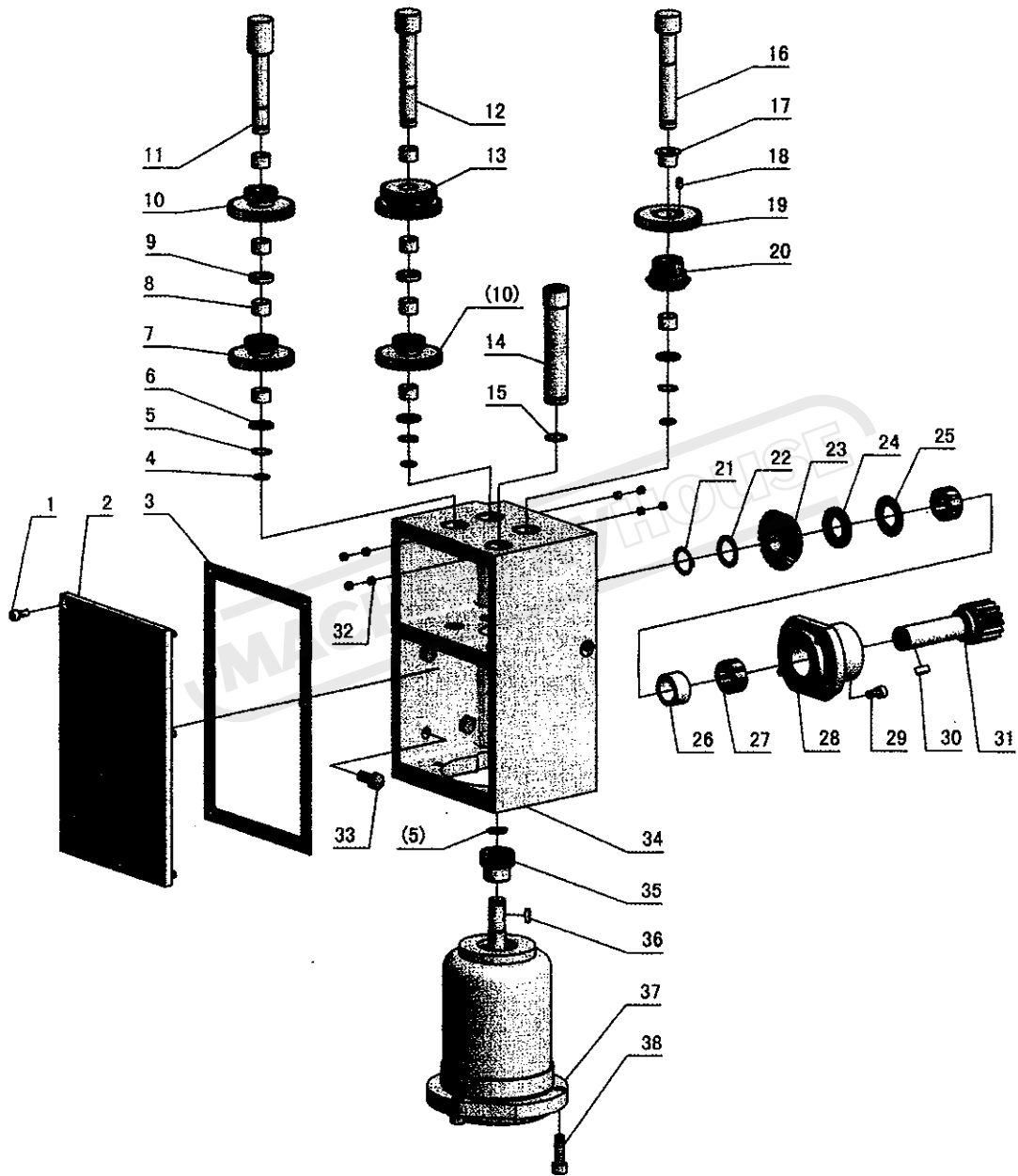

No.	Part No.	Name	Specifications	Qty.
1	GB70-85	Socket Head Cap Screw	M5×12	8
2	C6251A-19-08-04	Cover		1
3	C6251A-19-08-12	Cover Seal		1
4	GB/T3452.1-1992	O-Ring	Φ10.6×1.8	3
5	GB894.1-86	Snap Ring	14	4
6	C6251A-19-08-11	Spacer		3
7	C6251A-19-08-05	Gear I	Z36 × 1.5/Z17 ×	1
8	SF-1(DU)	Bearing	C/SF-1410	9
9	C6251A-19-08-10	Spacer		2
10	C6251A-19-08-06	Gear II	Z37 × 1.5/Z17 ×	2
11	C6251A-19-08-07	Shaft I		1
12	C6251A-19-08-08	Shaft II		1
13	C6251A-19-08-09	Gear III	Z37 × 1.5/Z31 ×	1
14	C6251A-19-08-24	Shaft		1
15	GB/T3452.1-1992	O-Ring	Φ16×1.8	1
16	C6251A-19-08-23	Shaft III		1
17	SF-1F	Bearing	C/SFF-14120	1
18	GB77-85	Screw	M5×8	3
19	C6251A-19-08-21	Gear	Z37×1.5	1
20	C6251A-19-08-22	Bevel Gear	Z21×1.75	1
21	GB894.1-86	Snap Ring	20	1
22	C6251A-19-08-20	Washer II		1
23	C6251A-19-08-15	Bevel Gear	Z29×1.75	1
24	GB/T4605-1984	Bearing	AXK 2035	1
25	C6251A-19-08-16	Washer I		1
26	C6251A-19-08-19	Spacer		1
27	GB/T5801-1994	Bearing	RNA 4902	2
28	C6251A-19-08-17	Bearing Cover		1
29	GB70-85	Socket Head Cap Screw	M6×12	4
30	GB1096-79	Key	5×14	1
31	C6251A-19-08-18	Pinion		1
32	GB80-85	Screw	M6×6	8
33	GB5783-86	Bolt	M8×20	4
34	C6251A-19-08-14	Box		1
35	C6251A-19-08-02	Gear	Z18×1.5	1
36	GB1096-79	Key	4×12	1
37	YS	Motor	YSS2-5634	1
38	GB70-85	Socket Head Cap Screw	M8×25	3

Chuck Guard Cover

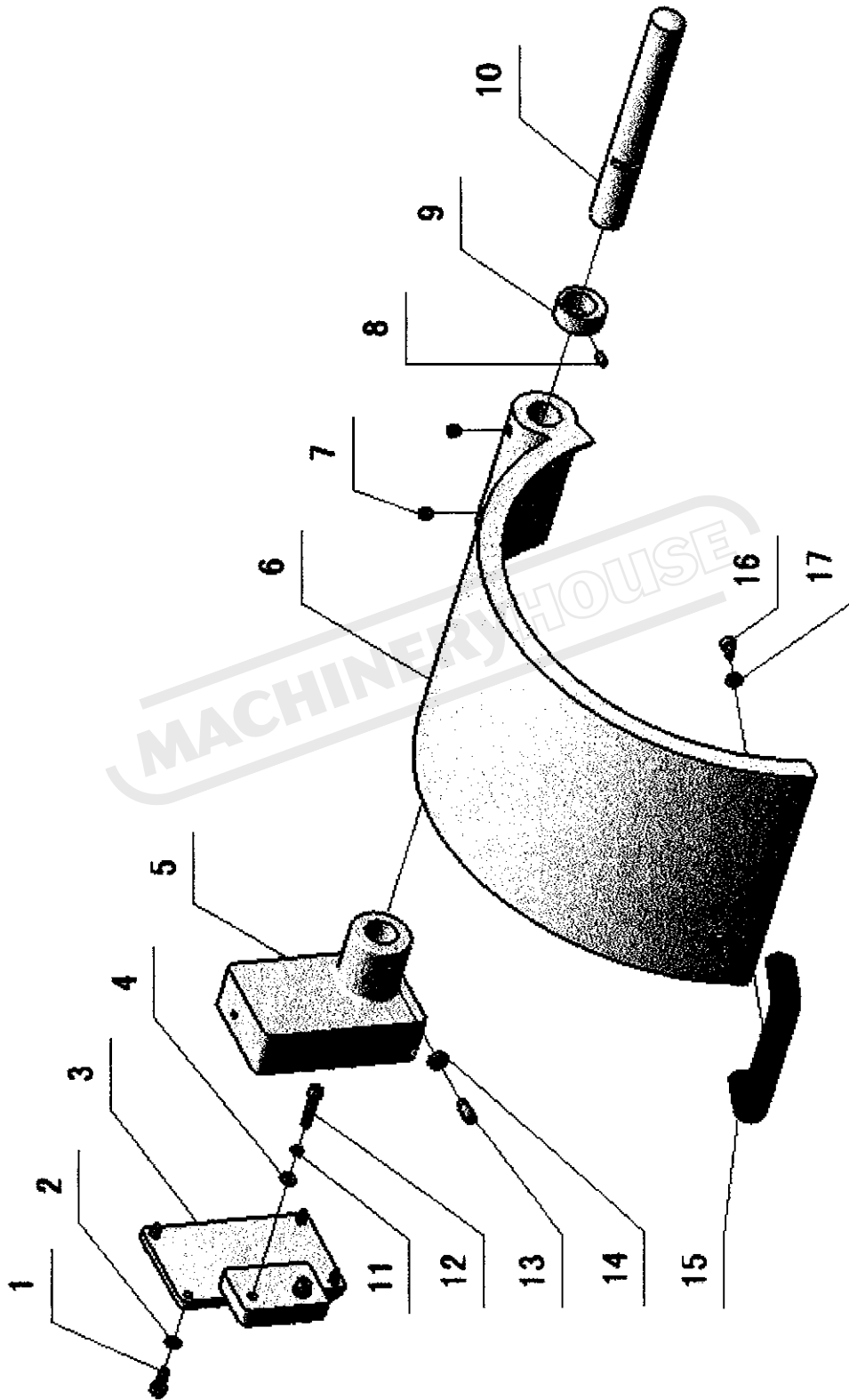

NO	Part No.	Name	Specification	Qty.
1	GB70-85	Screw	M6×16	4
2	GB93-87	Washer	6	4
3	RUN6246-F101002F	Support Bracket		1
4	GB97.1-85	Washer	6	2
5	RUN6246-101101	Bracket		1
6	C6241-16-01	Cover		1
7	GB80-85	Screw	M8×8	2
8	GB78-85	Screw	M6×10	1
9	CM6233-F1005	Cam		1
10	C6241-16-02	Shaft		1
11	GB93-87	Washer	6	2
12	GB70-85	Screw	M6×30	2
13	GB79-85	Screw	M8×20	1
14	GB6172-86	Nut	M8	1
15	HY8315.4	handle	A=114	1
16	GB70-85	Screw	M6×10	2
17	GB97.1-85	Washer	6	2

MACHINERYHOUSE

Operation Manual for

Copying Device of Horizontal Lathe*

“*” IS FOR USERS' SPECIAL ORDER

CONTENTS

(1) Main Data -----	102
(2) List of Parts -----	103-107
(3) Installation Method -----	108-110
(4) Operation Method -----	110-111

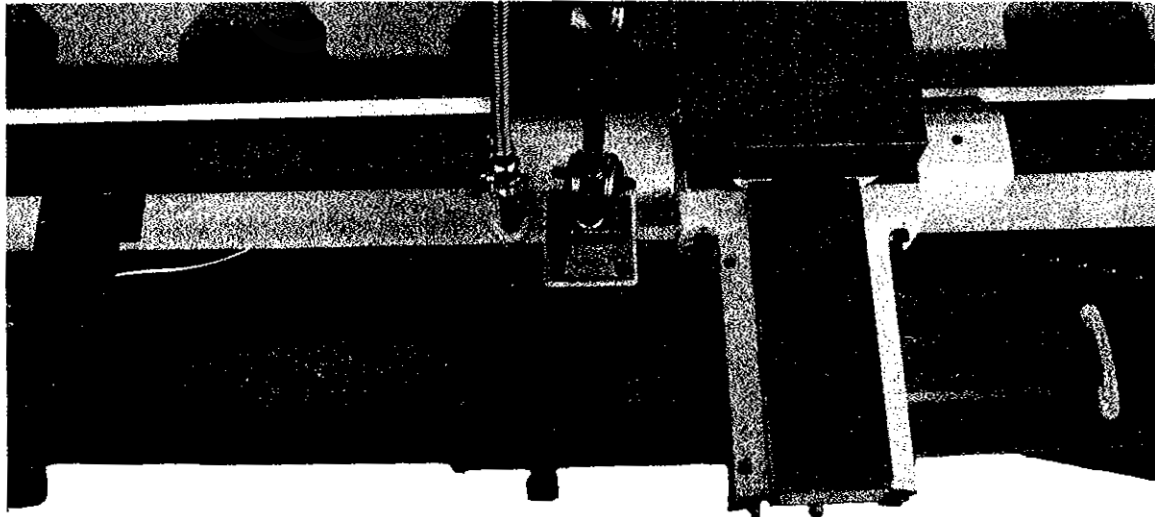

Figure 1

(1) Main Data

Stroke	455 mm
Angle	$\pm 8^\circ$
Packing Sizes (mm)	740 × 350 × 270
Net Weight (kg)	43 kg
Gross Weight (kg)	52 kg

MACHINERYHOUSE

(2) List of Parts

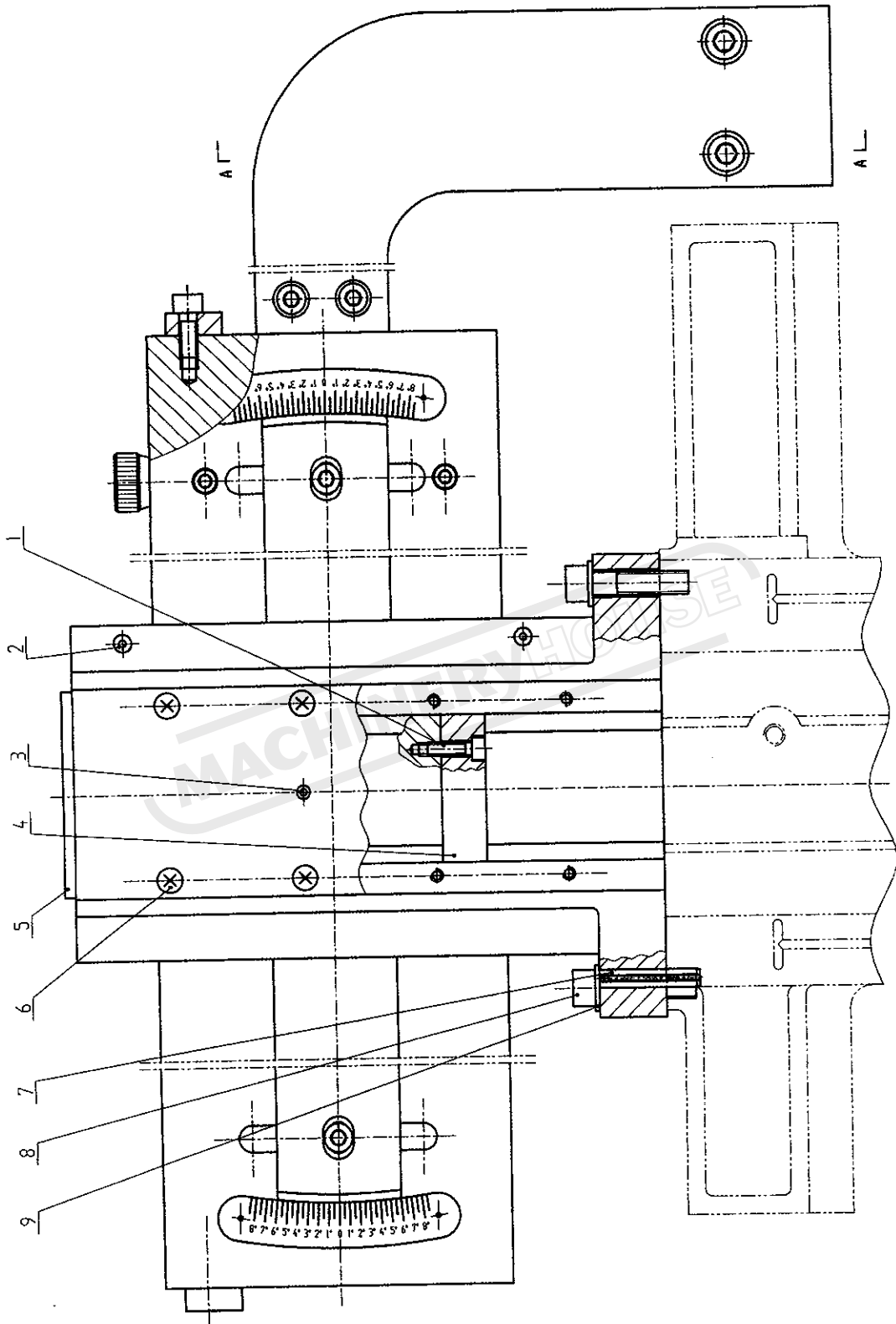

Figure 2

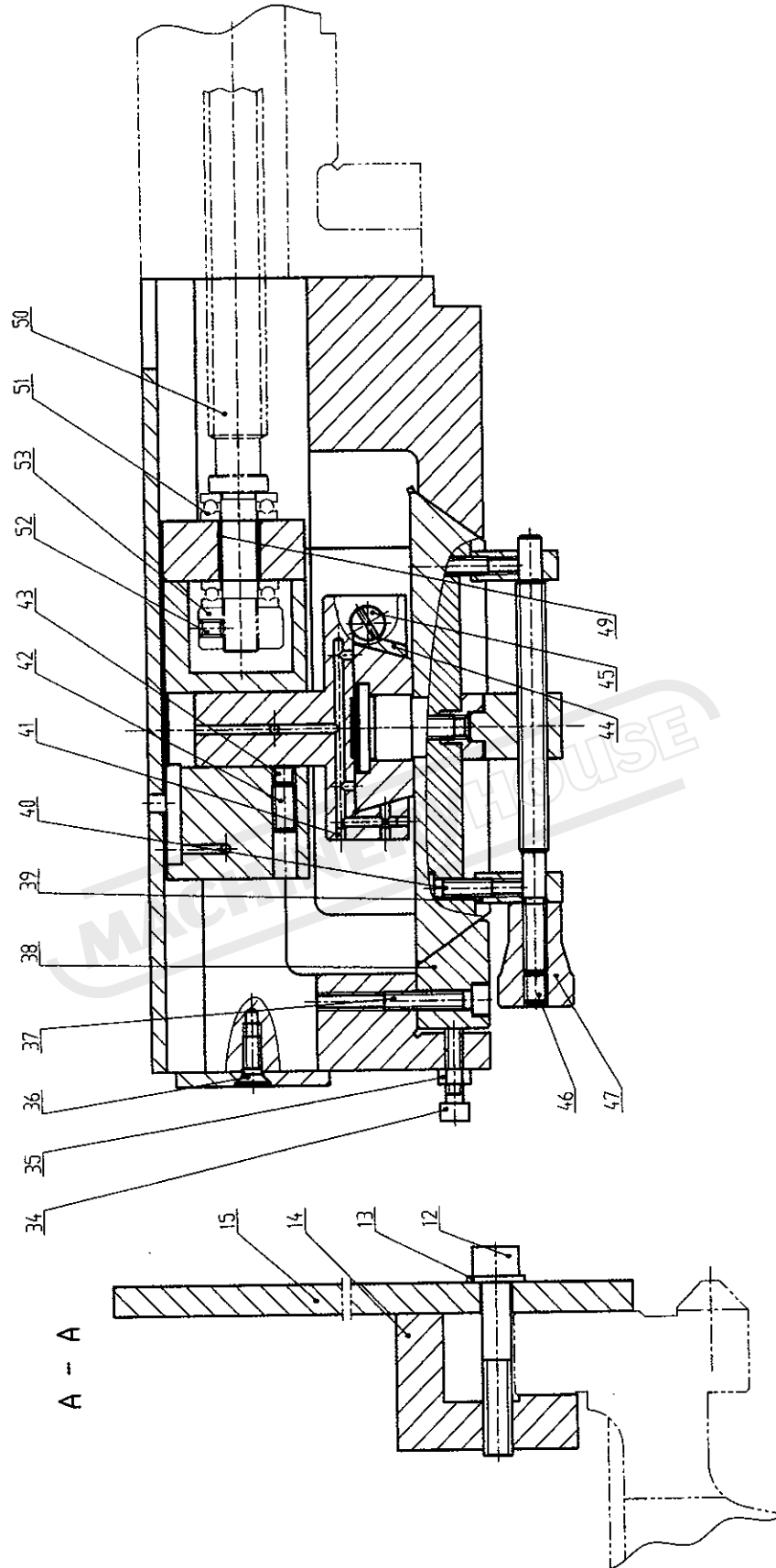

Figure 3

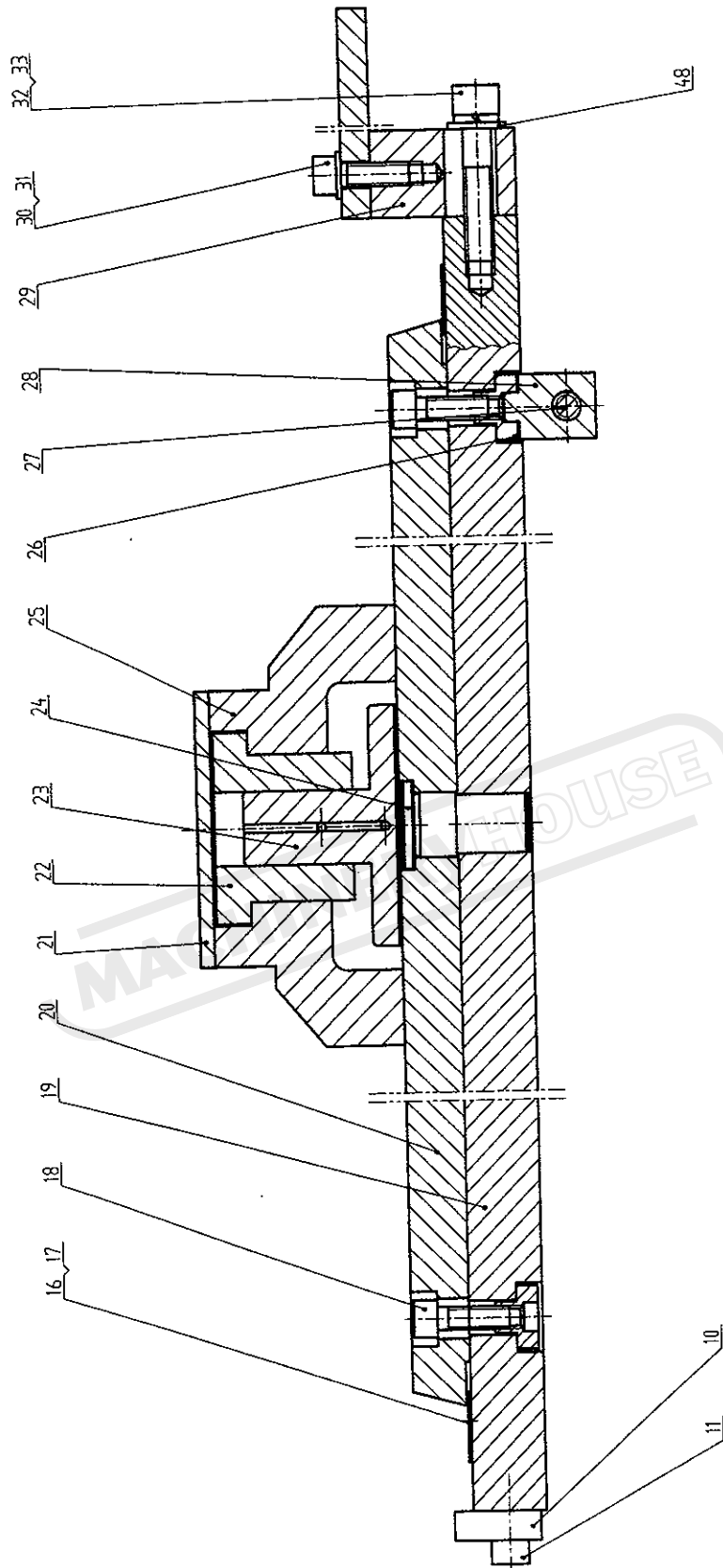

Figure 4

S/N	Code of Part	Name	Size	Quantity
1	GB70-85	Socket Cap Screw	M6×20	2
2	GB1155-89	Press-Fit Oil Cup	D=8	2
3	GB1155-89	Press-Fit Oil Cup	D=6	1
4	C6241-115001	End Block (for C6241, C6246H, C6251A,		1
4	C6266A-17-01	End Block (for C6266A)		1
5	C6241-115002	Stopper		1
6	GB819-85	Cross Recess Sunk Screw	M6×16	8
7	GB879-86	Spring Cylindrical Pin	8×45	2
8	GB70-85	Socket Cap Screw	M10×45	4
9	GB97.1-85	Flat Washer	d1=10	4
10	C6241-115003	Stopper		2
11	GB70-85	Socket Cap Screw	M8×20	2
12	GB70-85	Socket Cap Screw	M10×60	2
13	GB97.1-85	Flat Washer	d1=10	2
14	C6241-115033	Pressed Block (for C6241, C6246H,		1
14	C6251A-17-01	Pressed Block (for C6251A, C6256A)		1
15	C6241-115032	Pull Rod		1
16	GB827-86	Nails for Sign Board	2×6	4
17	C6241-115009	Sign Board		2
18	GB70-85	Socket Cap Screw	M8×25	2
19	C6241-115034	Profiling Seat		1
20	C6241-115012	Profiling Plate		1
21	C6241-115013	Press Plate Cover		1
22	C6241-115014	Slide Block		1
23	C6241-115015	Pivot		1
24	C6241-115016	Position Axle		1
25	C6241-115017	Main Support		1
26	C6241-115018	Mobile Block		2
27	C6241-115019	Adjustment Screw		1
28	C6241-115020	Adjustment Nut		1

S/N	Code of Part	Name	Size	Quantity
29	C6241-115031	Connection Block (for C6241, C6246H, C6251A, C6256A)		1
29	C6266A-17-02	Connection Block (for		1
30	GB70-85	Socket Cap Screw	M8×25	2
31	GB97.1-85	Flat Washer	d1=8	2
32	GB70-85	Socket Cap Screw	M10×50	2
33	GB93-86	Spring Washer	10	2
34	GB70-85	Socket Cap Screw	M6×25	3
35	GB6170-86	Model 1 Hexagon Nut –	M6 zinc	3
36	GB819-85	Cross Recess Sunk Screw	M6×16	2
37	GB70-85	Socket Cap Screw	M6×30	3
38	C6241-115024	Wedge		1
39	C6241-115025	Adjustment Supporter		2
40	GB70-85	Socket Cap Screw	M6×20	2
41	C6241-115026	Block Pin		3
42	GB77-85	Socket Flat Set Screw	M8×16	1
43	C6241-115027	Copper Washer		1
44	C6241-115028	Inlaid Strip		1
45	C6241-115029	Press Screw		2
46	GB77-85	Socket Flat Set Screw	M8×10	1
47	C6241-115030	Handle		1
48	GB97.1-85	Flat Washer	d1=10 zinc	2
49	SF-1	Oil-Free Lubrication	1218	1
50	RUN6141-103021	Guide Screw		1
51	GB/T 301-1995	Thrust Ball Bearing	51101	2
52	GB80-85	Socket Recess Set Screw	M6×8	1
53	RUN6246-103007-1	Nut		1

(3) Installation Method

- 3.1 Remove the back plate of the lather for easy installation of the copying device.
- 3.2 Loosen the socket recess set screw 54 in Figure 5, remove the nut 55; draw up the position pin 60 in A-Direction View in Figure 5, remove the socket cap screw 59 and remove the rear supporter 57 and the thrust ball bearing 56 in Figure 5 at last.

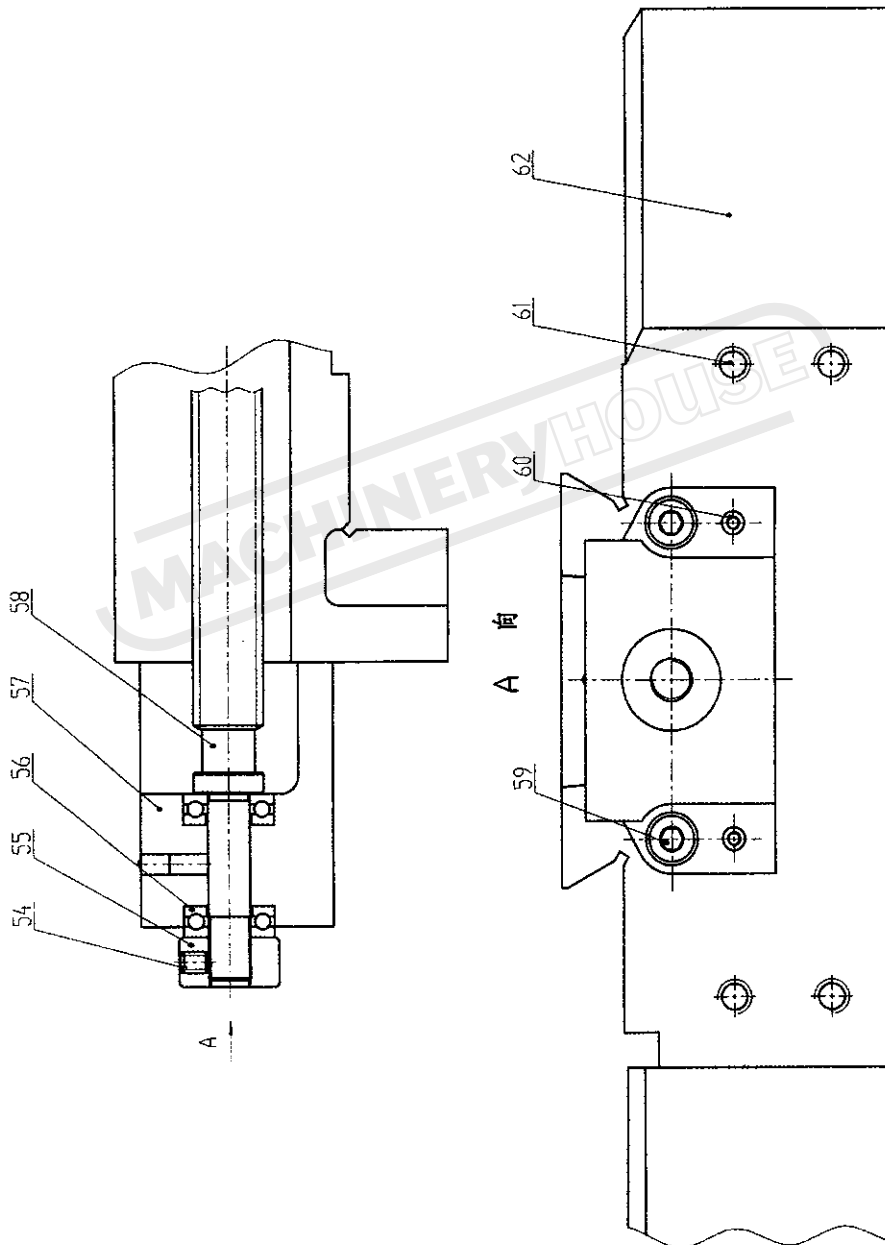

Figure 5

- 3.3 Remove the cross recess sunk screw 6 in Figure 2 and the press plate cover 21 in figure 4; loosen the socket flat set screw 42 in Figure 3, remove the slide block 22 in Figure 4, the end block 4 in Figure 2 and the socket cap screw 1 .
- 3.4 According to Figure 3, fix the guide screw 50, the thrust ball bearing 51 and the nut 53 on the end block 4 in Figure 2, adjust the axial playing of the guide screw 50 in Figure 3, fix the nut 53 by means of the socket recess set screw 52, mount the end block 4 in Figure 2 into the slide block 22 in Figure 4 by means of the socket cap screw 1.
- 3.5 Mount the remaining part of the copying device into the screw hole 61 on the bed saddle 62 in Figure 5 by means of the socket cap screw 8 and the flat washer 9 in Figure 2. Take care to insert the cylindrical part of the pivot 23 in Figure 4 into the hole of the slide block 22.
- 3.6 Mount the one end of the pull rod 15 on the connection block 29 by means of the socket cap screw 30 and the flat washer 31 in Figure 4, and fix the other end and press block 14 in Figure 3 on the plane guide rail of the bed by means of the socket cap screw 12 and the flat washer 13, tighten the socket cap screw 12 to fix relatively the pull rod 15 with the bed.
- 3.7 Fix the indicator according to the way in Figure 6. Move the carriage leftward or rightward and calibrate the upper face of the profiling seat 19 to be ≤ 0.05 mm in Figure 4, drill the position pinhole $\phi 8$ on the bed saddle 62 in A-Direction View in Figure 5 by the electric hand drill and mount the spring cylindrical pin 7 in Figure 2.

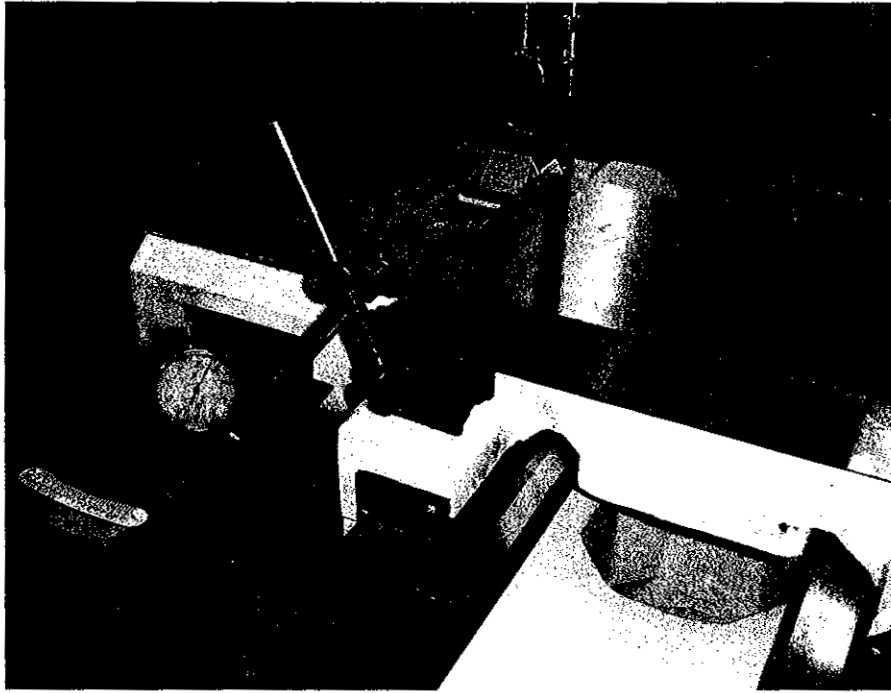

Figure 6

- 3.8 Turn the guide screw 50 in Figure 3 to make it move axially and knock the upper face of the slide block 22 in Figure 3 by wooden hammer at the same time. In case when the guide screw turning is free, fix the slide block 22 and the pivot 23 in Figure 4 by means of the socket cap set screw 42 in Figure 3 (take care the socket flat set screw 42 cannot press the pivot 23 too tight).
- 3.9 According to Figure 2 mount the press plate cover 21 in Figure 4 by means of the cross recess sunk screw 6 and loosen the socket caps crew 12 in Figure 3.
- 3.10 Mount the back plate on the position as the original status to complete the whole installation course.

(4) Operation Method

- 4.1 Before operation, move the carriage in front of the taper face to be turned, tighten the socket cap screw 12 in Figure 3 to lock the pull rod 15 in Figure 3 tightly on the bed.
- 4.2 Loosen the socket cap screws 18 in Figure 4 (one each at the both ends), turn the handle 47 in Figure 3 to adjust the required taper, then lock the socket cap

- screws 18 in Figure 4 (one each at the both ends).
- 4.3 When running the tool on the carriage longitudinally, the guide screw 50 and the lateral slide plate are driven by the pivot 23 and the slide block 22 in Figure 4 to finish the function to turn the taper.
- 4.4 When it is not in use, loosen the socket cap screws 18 in Figure 4 (one each at the both ends), turn the handle 47 in Figure 3 to adjust the profiling plate 20 to “zero” position, then lock the socket cap screws 18 in Figure 4 (one each at the both ends), loosen the socket cap screw 12 in Figure 3 to make all other normal turning.

MACHINERYHOUSE